

## SERIES 25A SERVO AMPLIFIERS

### Models: 12A8, 25A8, 20A14, 20A20

### Miniature Series

**FEATURES:**

- Surface-mount technology
- Small size, low cost, ease of use
- DIP switch selectable: current, voltage, velocity, analog position loop
- Four quadrant regenerative operation
- Agency Approvals:



**BLOCK DIAGRAM:**

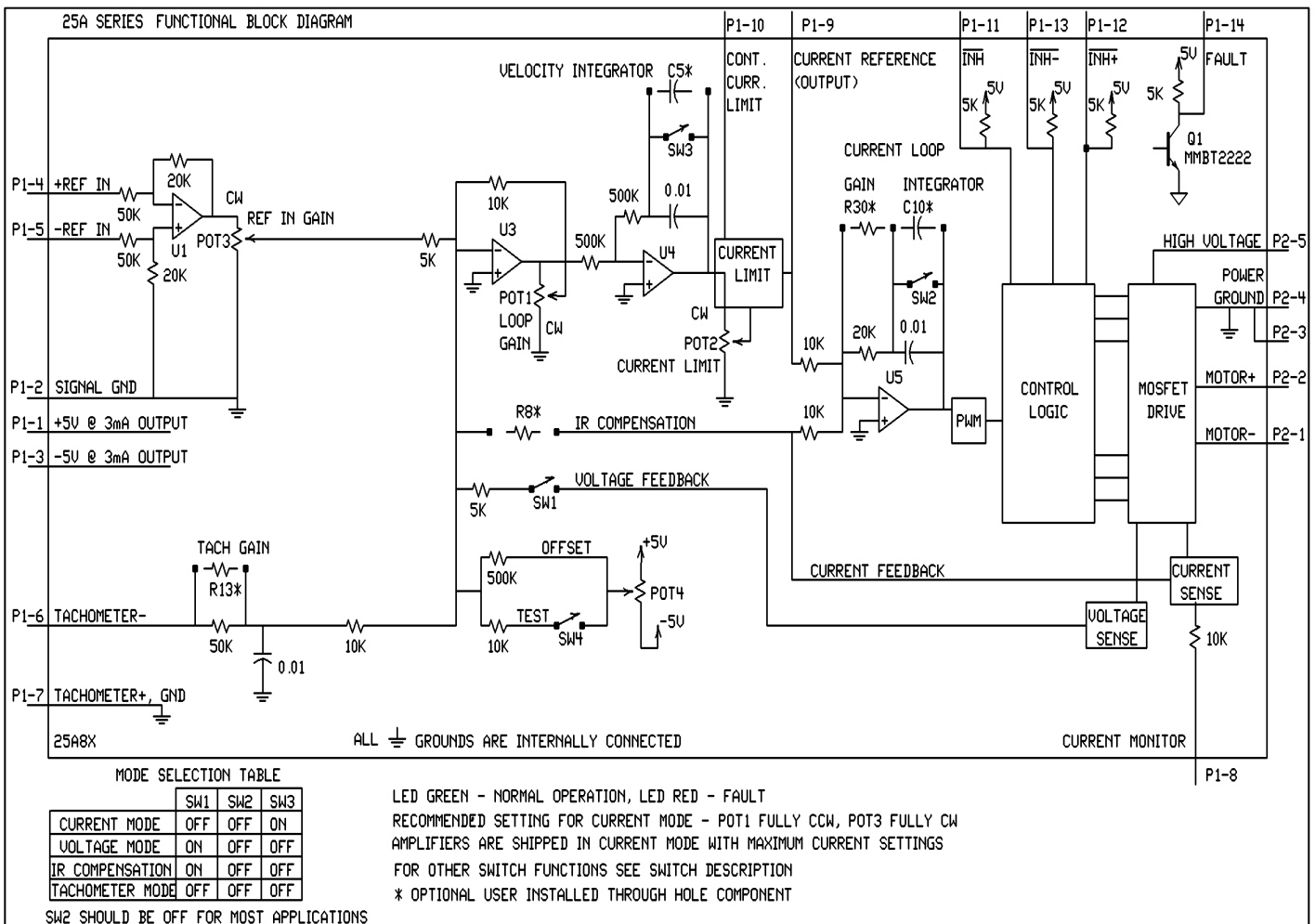

**DESCRIPTION:** The 25A Series PWM servo amplifiers are designed to drive brush type DC motors at a high switching frequency. A single red/green LED indicates operating status. All models are fully protected against over-voltage, over-current, over-heating and short-circuits across motor, ground and power leads. All models interface with digital controllers or can be used as a stand-alone drive. They require only a single unregulated DC power supply. Loop gain, current limit, input gain and offset can be adjusted using 14-turn potentiometers. The offset adjusting potentiometer can also be used as an on-board input signal for testing purposes when SW4 (DIP switch) is ON.

**SPECIFICATIONS:**

POWER STAGE SPECIFICATIONS	MODELS			
	12A8	25A8	20A14	20A20
DC SUPPLY VOLTAGE	20 - 80 V	20 - 80 V	40 - 140 V	40 - 190 V
PEAK CURRENT (2 sec. Max., internally limited)	± 12 A	± 25 A	± 20 A	± 20 A
MAXIMUM CONTINUOUS CURRENT (internally limited)	± 6 A	± 12.5 A	± 10 A	± 10 A
MINIMUM LOAD INDUCTANCE*	200 µH	200 µH	250 µH	250 µH
SWITCHING FREQUENCY	36 kHz	22 kHz ± 15%		
HEATSINK (BASE) TEMPERATURE RANGE	0 ° to + 65°C, disables if > 65°C			
POWER DISSIPATION AT CONTINUOUS CURRENT	24 W	50 W	70 W	100 W
OVER-VOLTAGE SHUT-DOWN (self-reset)	86 V	86 V	142 V	195 V
BANDWIDTH (load dependent)	2.5 kHz			

MECHANICAL SPECIFICATIONS	
POWER CONNECTOR	Screw terminals
SIGNAL CONNECTOR	Molex connector
SIZE	5.09 x 2.98 x 0.99 inches 129.3 x 75.8 x 25.1 mm
WEIGHT	10 oz. 0.28 kg

\* Low inductance motors ("pancake" and "basket-wound") require external inductors.

## PIN FUNCTIONS:

CONNECTOR	PIN	NAME	DESCRIPTION / NOTES	I/O
P1	1	+5V OUT	Internal DC-to-DC converter, outputs regulated voltages of $\pm 5$ V @ 3 mA for customer use. Short circuit protected.	O
	2	SIGNAL GND		GND
	3	-5V OUT		O
	4	+REF IN	Differential analog input, maximum $\pm 15$ V, 50K input resistance.	I
	5	-REF IN		
	6	-TACH IN	Maximum $\pm 60$ VDC, 60K input resistance.	I
	7	+TACH (GND)		
	8	CURRENT MONITOR OUT	This signal is proportional to the actual current in the motor leads. Scaling is 2A/V for 12A8 and 4 A/V for 25A8, 20A14 and 20A20.	O
	9	CURRENT REFERENCE OUT	Command signal to the internal current-loop. The maximum peak current rating of the amplifier always equals 7.25V at this pin. See current limit adjustment information below.	O
	10	CONTINUOUS CURRENT LIMIT	Can be used to reduce the factory-preset maximum continuous current limit.	I
	11	INHIBIT	This TTL level input signal turns off all four power devices of the "H" bridge drive when pulled to ground. This inhibit will cause a FAULT condition and a red LED. For inverted inhibit inputs; see section "G".	I
	12	+INHIBIT	Disables the amplifier for the "+" direction only. This inhibit will not cause a FAULT condition or a red LED.	I
	13	-INHIBIT	Disables the amplifier for the "-" direction only. This inhibit will not cause a FAULT condition or a red LED.	I
	14	FAULT OUT (red LED)	TTL compatible output. It becomes high during output short-circuit, over-voltage, over-heating, inhibit, and during "power-on reset". Fault condition indicated by a red LED.	O
	15	NC	Not connected	
	16			
P2	1	-MOTOR	Motor minus connection.	O
	2	+MOTOR	Motor plus connection.	O
	3	POWER GROUND	Power Ground.	GND
	4	POWER GROUND	Power Ground.	GND
	5	HIGH VOLTAGE	DC voltage input.	I

**SWITCH FUNCTIONS:**

SWITCH	FUNCTION DESCRIPTION	SETTING	
		ON	OFF
1	Internal voltage feedback	On	Off
2	It is recommended to leave SW2 in OFF position.	Shorts out the current loop integrator capacitor.	Current loop integrator operating
3	This capacitor normally ensures "error-free" operation by reducing the error-signal (output of summing amplifier) to zero.	Shorts out the outer velocity/voltage loop integrator capacitor	Velocity/Voltage integrator operating
4	Offset / test. Controls sensitivity of the "offset" pot. Used as an on-board reference signal in test mode.	Test	Offset

**POTENTIOMETER FUNCTIONS:**

POTENTIOMETER	DESCRIPTION	TURNING CW
Pot 1	Loop gain adjustment in voltage & velocity modes. Turn this pot fully ccw in current mode.	Increases loop gain
Pot 2	Current limit. It adjusts both continuous and peak current limit by maintaining their ratio (50 %).	Increases current limit
Pot 3	Reference gain. It adjusts the ratio between input signal and output variables (voltage, current, or velocity).	Increases reference input gain
Pot 4	Offset / test. Used to adjust any imbalance in the input signal or in the amplifier. When SW4 (DIP switch) is ON, the sensitivity of this pot is greatly increased thus it can be used as an on-board signal source for testing purposes. See section "G".	N/A

**TEST POINTS FOR POTENTIOMETERS:** See section "G"

**SET-UP:** See section "G" for engineering and installation notes.

### OPERATING MODE SELECTION:

These modes can be selected by the DIP-switches according to the chart in the functional block diagram:

- Current Mode
- Voltage Mode
- IR Compensation Mode\*
- Tachometer Mode

### APPLICATION NOTES:

\*For IR compensation mode, a resistor must be added to location R8\*. See the functional block diagram above and section "G" for more information. The combination of the resistor addition and the switches set for voltage mode will configure the amplifier for IR compensation mode. See section "G" for more information.

See section G for more information on analog position loop mode.

### CURRENT LIMIT ADJUSTMENTS:

These amplifiers feature separate peak and continuous current limit adjustments.

The current limit adjusting Pot 2 adjusts both peak and continuous current limit at the same time. It has 12 active turns plus 1 inactive turn at each end and is approximately linear. Thus, to adjust the current limit, turn the potentiometer fully counter-clockwise, then turn clockwise to the appropriate value. If the desired limit is, for example, 10 amperes, and the servo amplifier peak current is 20 amperes, turn the potentiometer 7 turns clockwise from the fully counter-clockwise position.

Pin P1-9 is the input to the internal current amplifier stage. Since the output current is proportional to P1-9, the adjusted current limit can easily be observed at this pin. Note that a command signal must be applied to the reference inputs to obtain a reading on P1-9. The maximum peak current value equals 7.25 V at this pin and the maximum continuous current value equals 3.63 V at this pin.

The actual current can be monitored at pin P1-8.

The continuous current can be reduced without affecting the peak current limit by connecting an external current limiting resistor R-lmt between P1-10 and P1-2. See table below.

Current Limit Resistor ( $\Omega$ )	15K	6.6K	3.4K	2.1K	1.2K	810	500	250	0
Continuous Current Limit %	90 %	80 %	70 %	60 %	50 %	40%	30 %	20 %	10 %

**TYPICAL SYSTEM WIRING:** See section "G".

25A Series

**ORDERING INFORMATION:**

Models: 12A8X, 25A8X, 20A14X, and 20A20X

X indicates the current revision letter.

**MOUNTING DIMENSIONS:** See page F-7.

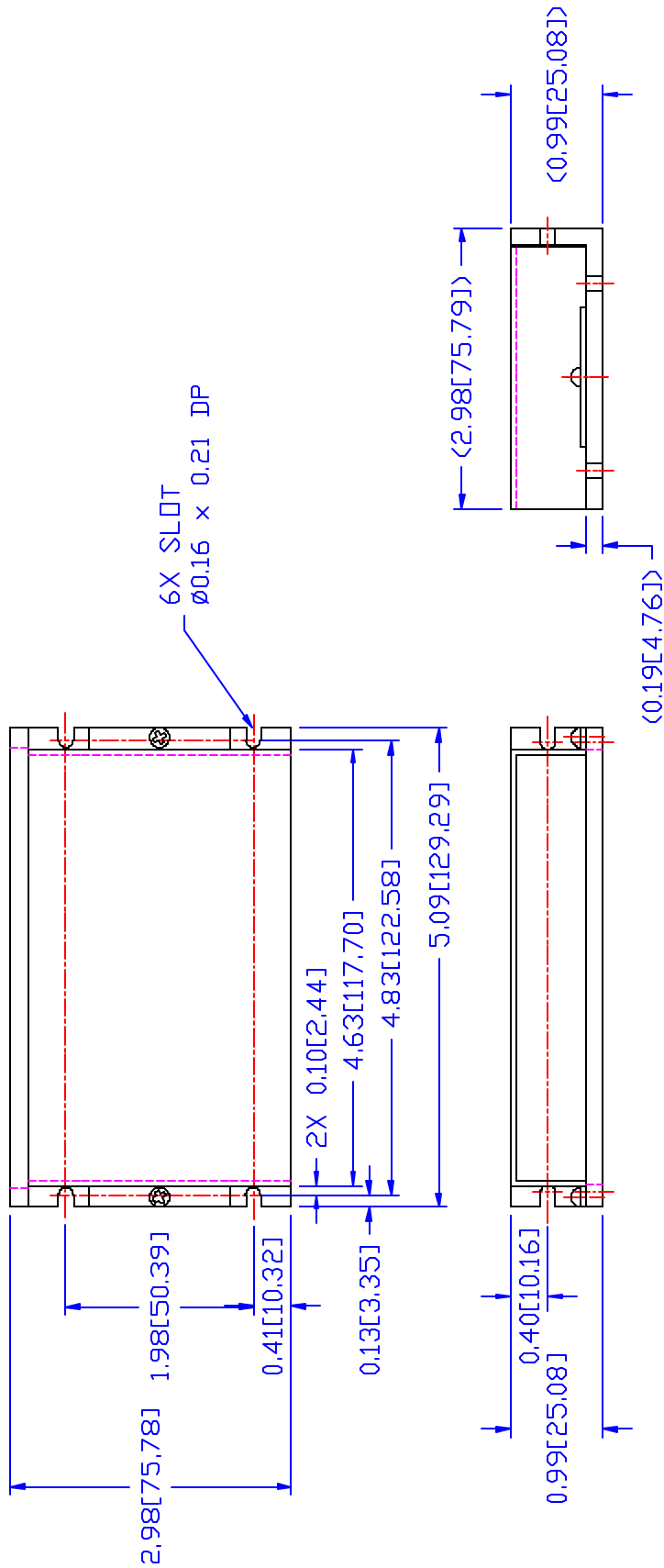

NOTE: DIMENSIONS IN [ ] ARE IN MM.

B	CHANGE ADDRESS ON TITLE BLOCK	09/18/01	RB
A	UPDATE DWG. FORMAT	08/22/96	RB
REV	DESCRIPTION	DATE	BY
UNLESS OTHERWISE SPECIFIED, DIMENSIONS ARE IN INCHES TOLERANCES .XX ± .010 .XXX ± .005 DO NOT SCALE DRAWING			
DRAWN BY: ROBERTO		DATE: 09/27/95	
CHECK BY:		DATE:	
DESIGN APPROVED:		DATE:	
USED ON			
BE15A SERIES			
B15A SERIES			
BD15A SERIES			
25A SERIES			
ADVANCED MOTION CONTROLS PWM SERVO AMPLIFIERS • 9805 Calle Tecate, Cananillo, CA 95002			
TITLE MOUNTING DIMENSIONS			
B12A, 25A, BE12A SERIES			
SIZE	DWG. NO.	REV	
B	MB12A	B	
SCALE: NONE			SHT. 1 OF 1