

## APPENDIX B - MOUNT SPECIFIC DATA

### For

### VERTEX 2.4m. SM-LT

This appendix describes RC3000 operations unique for the Vertex 2.4m. SM-LT mount.

Revision History. Date: 29 October 2004 - Software Version: 1.45

#### 1.1 Manual Organization

This appendix is provided as a supplement to the baseline RC3000 manual. Differences between this version and the operation described in the baseline RC3000 manual are noted on a paragraph by paragraph basis.

#### 1.2 RC3000 Features

All features described in the baseline manual are supported.

**Hardware Configuration.** A RC3000E version of hardware is required for this mount. The E model is similar to a RC3000A (low voltage drive) model but the chassis backpanel contains the correct connectors to mate with standard Vertex/RSI MVO-style cables.

**Software Configuration.** Two software versions support this mount.

Software version VE will support the 2.4 SM-LT mount for all RC3000 units.

Software version VF is similar to VE plus it supports an additional feature that will monitor elevation current during the stow process. Version VF is only available for use on RC3000 units containing the newer "A2" style hardware. NOTE: RC3000s with "A2" style hardware will have serial numbers starting with -2000.

Software will be designated as RC3K-VE-xxx or RC3K-VF-xxx. Both versions are described in this appendix. Unique items only applicable to VF software will be noted.

##### 1.3.1 Controller Description

RESOLVER BOARD. To support the VE/VF versions, the optional resolver to digital conversion board must be added to the baseline RC3000 hardware.

##### 1.3.2 System Interface Requirements

The following unique interface requirements exist for the VE/VF versions:

- The MVO's CCW polarization limit switch drives the RC3000's polarization stow limit input
- Feed type is sensed via the RC3000 inputs normally used to sense pulse inputs.
- No azimuth potentiometer exist, a resolver is used for sensing azimuth position and for performing high resolution movements in azimuth. A resolver is used for high resolution movements in elevation.

##### 1.3.3 Operational Overview

Operation of the VE/VF versions is almost identical to that described in the baseline manual. Differences will be noted in the appropriate paragraphs.

### 1.3.7 Drive System

**Position Sensing and Limits.** In addition to azimuth cw and ccw limit switches, azimuth software limits are implemented. An elevation UP software limit is also implemented for this version.

**Jam and Runaway Sensing.** Jammed and runaway sensing is based on resolver counts.

## 2.0 INSTALLATION

### 2.1.1 RC3000 Antenna Controller

The RC3000E is slightly deeper (19.1" vs. 17.05") than the baseline RC3000. This additional depth is required to accommodate the backpanel with MVO-style connectors.

### 2.1.4 Electronic Clinometer

The inclinometer should be rigged with the face vertical. With the face vertical, the inclinometer should be mounted so that it is 19.0 (35.0 –16.0) degrees from vertical. This orientation will allow linear output from the inclinometer to a RF angle of 90 degrees.

## 2.2 Electrical Connections.

The RC3000E's backpanel contains the standard connectors for use with the RSI MVO's antenna status (J8) and motor control (J9) cabling. The following diagram shows this backpanel.

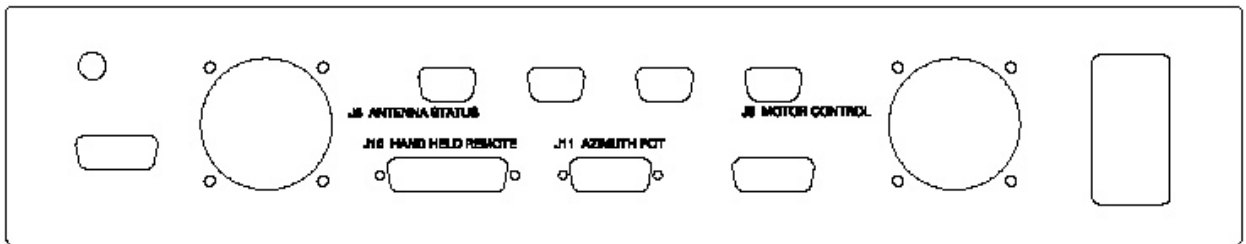

### 2.2.1 Power Entry

The RC3000E has the same fuse requirements as the RC3050A model (8 A. for 115, 4 A. for 230).

### 2.2.2 Motor Drive

### 2.2.3 Drive Sense

### 2.2.4 Limit Switches

### 2.2.7 Accessories

### 2.2.10 Pulse Sensors

Internal to the RC3000E is cabling that adapts these standard interface connections shown in the baseline manual to the MVO style connectors on the backpanel. Schematics are provided in section 4.2 showing this adaptation.

NOTE: the RC3000's Pulse Sensor inputs are used for sensing the status of the MVO's feed type inputs. The mechanization of these inputs is shown in the adapter cable schematic.

The individual MVO style connectors are now discussed.

**Motor Control.**

Azimuth, elevation and polarization drive commands along with azimuth and elevation brake control is provided via J9. J9 is a female 35 pin Amphemnol MS (size 28-15) type connector.

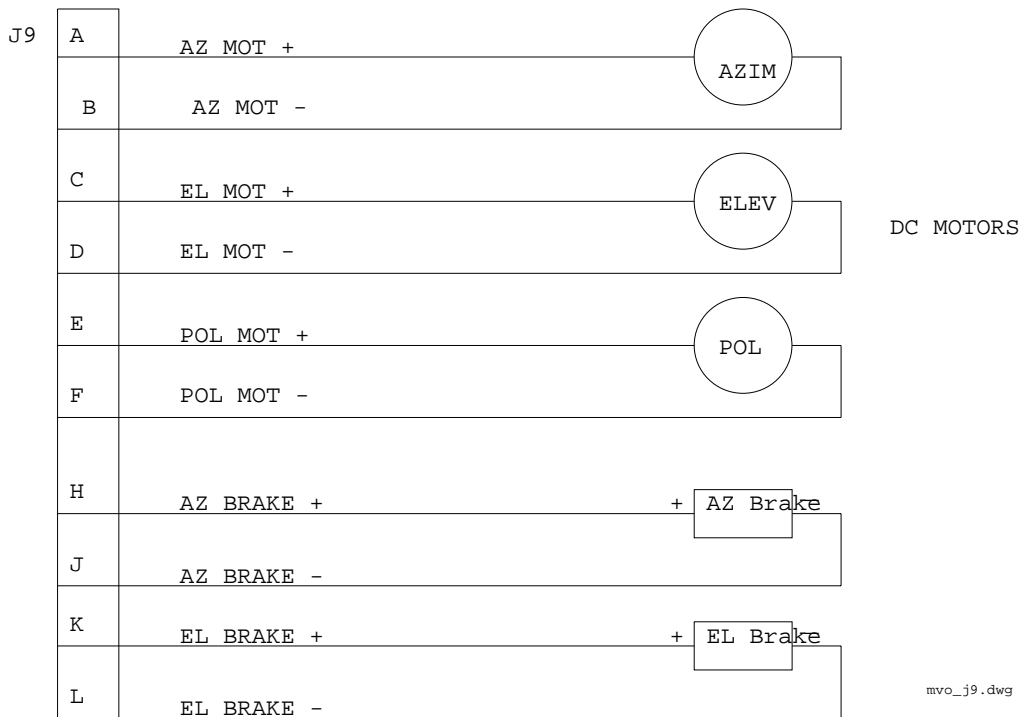

**Antenna Status.**

Limit switch status, feed type status, polarization and elevation position is provided via the J8 connector. J8 is a female 37 pin Amphemnol MS (size 28-21) type connector.

Pinouts for the J8 connectors are shown on the following page.

**2.2.13 Resolver inputs**

J11 and J7 are used for the azimuth and elevation resolver interfaces.

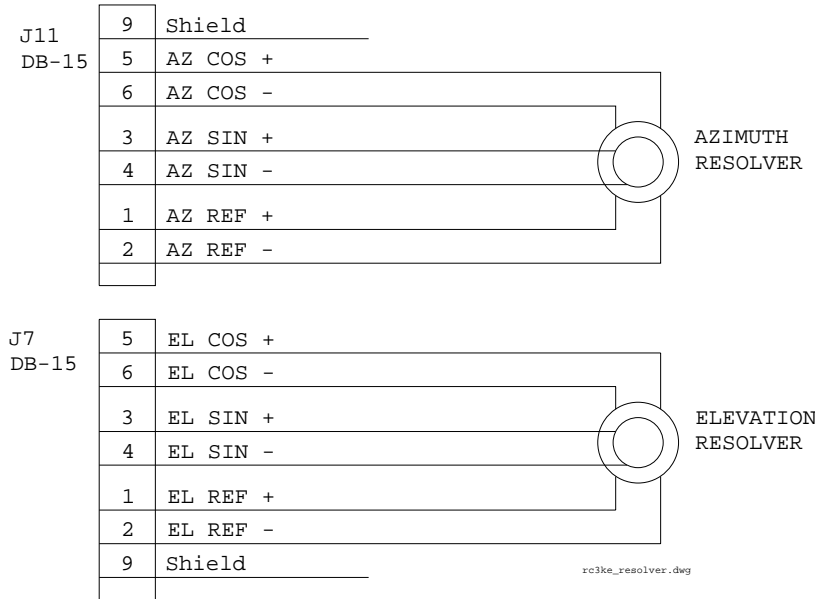

**2.2.5 Signal Strength**

NOTE: The gain and offset potentiometers associated with the signal strength connector are recessed from the backpanel on the RC3000E model. The lid of the RC3000 will have to be removed in order to calibrate these pots. This connector is designated J2 on the 3000E backpanel.

**2.2.6 Navigation Sensors**

On “baseline” RC3000’s the J9 connector is a 37 pin connector. An adapter “dongle” is supplied that adapts the DB-37 to two DB-9 connectors.

The RC3000E model supplies the two DB-9 connectors (J4-GPS, J5-Fluxgate) directly on the backpanel. Pinouts for these DB-9s are as shown in the baseline manual.

**2.2.8 RF Autopeak** Designated as J1 for RC3000E.

**2.2.11 PC Remote Control** Designated as J3 for RC3000E.

These connectors are provided on the backpanel of the RC3000E. Their function is as described in the baseline manual.

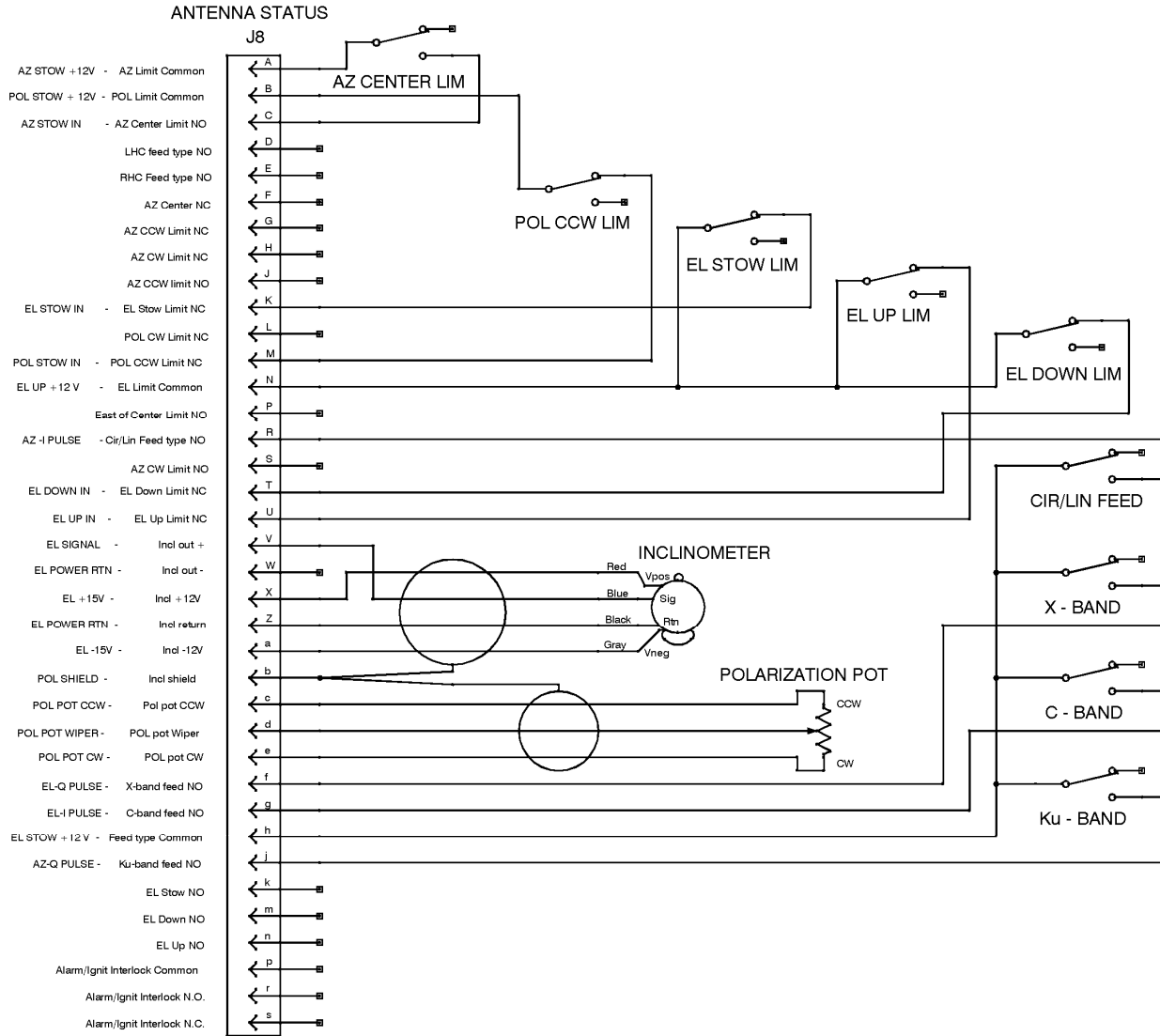

## 2.3 Initial Configuration

### 2.3.1 Software Initialization

Reset Defaults. The table at the end of the document supplies the default configuration item values for the VE and VF versions.

NOTE: All configuration item values should be examined to determine if they are appropriate for your specific installation.

### 2.3.2 Elevation Calibration

Elevation calibration will be as described in the baseline manual.

Elevation Reference Position. Both the inclinometer and elevation resolver should be calibrated while the antenna's face is vertical (i.e. the elevation reference position).

With the inclinometer oriented as described in 2.1.4 the elevation reference voltage should be approximately 0.81 volts.

**VF:** The stow current limit (3.3.1.3.10) will need to be set to the value required to obtain the correct amount of stow "preload".

### 2.3.3 Azimuth Calibration.

The only position sensor on the azimuth axis is a resolver. Azimuth calibration will be as described in the baseline manual.

Azimuth Limits. In addition to using CW and CCW limit switch inputs, this version of the RC3000 implements "software" limits. The azimuth CW and CCW pulse limits (3.3.1.3.3) should be set to values that reflect the azimuth resolver count values near the end of azimuth travel. When the RC3000 senses that the azimuth axis has reached these values, it will generate a "software" limit condition even though the actual hardware limit has not been reached. If the user does not want to use the "software limit" feature, set these configuration items to values outside the range of normal azimuth travel.

### Auxiliary Down Region Calibration.

The VE/VF versions implement an "auxiliary down region" that allows the mount to achieve lower elevation look angles (in some areas of travel) than is normally permitted. Compare the following drawing to the drawing in section 1.3.7 of the baseline manual. The auxiliary down region prevents the mount's feed boom from contacting the top of the vehicle when the azimuth position is near the center of travel. This auxiliary region is defined by software values as discussed in section 3.3.1.3.14.

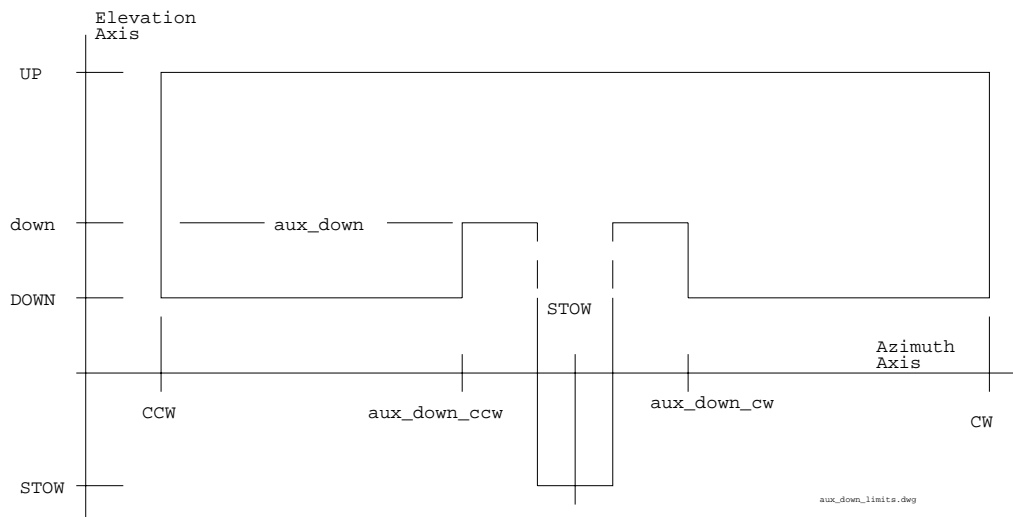

When outside of the auxiliary region, the down limit is defined by the hardware elevation down limit switch. The auxiliary down region allows the hardware limit switch to be set lower than normal.

To define the auxiliary down region, move the antenna clockwise and counterclockwise to azimuth positions where the boom can safely move below obstructions on the top of the vehicle. Note the azimuth resolver count at these positions. These counts will define the `aux_down_ccw` and `aux_down_cw` values.

Also note the elevation resolver count that the boom needs to stay above to ensure that the top of the vehicle will not be contacted. This count will define the `aux_down` value.

Having recorded the `aux_down_ccw`, `aux_down_cw` and `aux_down` resolver counts, go to the AUX\_DOWN configuration screen (3.3.1.3.14) and enter the values.

When elevation movement is restricted by the auxiliary down software values, the elevation limit field in the MANUAL mode will display “down” vs. “DOWN” which is displayed when the hardware limit is encountered.

**NOTE:** If one does not care to implement an auxiliary down region, set the `aux_down` value to a count that is below the hardware down limit position. This will effectively keep the “down” limit indication from happening.

### 2.3.4 Polarization Calibration.

Separate reference voltages are maintained for the three linear feed types. At power up the linear feed type is sensed and the reference voltage stored for that feed type is used. Therefore the reference voltage for each linear feed type used should be separately set.

**VF:** The POL CW limit is mechanized via the mount’s limit switch vs. the ACU POL CW pot.

### 3.2.1 Manual Mode.

If the feed type input has sensed that a circular polarized feed is installed, no POL field will be displayed since the RC3000 assumes that there is no need for polarization feedback from a circular polarized system.

The azimuth angle is generated as a function of the azimuth resolver feedback. Elevation angle represents true mount elevation based on feedback from the inclinometer. The scroll up key will switch the display between azimuth and elevation angles to resolver “counts”.

When elevation is below the DOWN limit, the displayed elevation angle will be derived from the elevation resolver.

When the auxiliary down region is active the limit display will indicate “down” vs. “DOWN”.

**VF:** the VF version allows for a fourth signal channel to be monitored. The Scroll/Dn key will allow the user to scroll through RF/SS1/SS2/CH4. CH4 is the channel that will be used to monitor elevation drive current. **NOTE:** below the DOWN limit, the display will be forced to CH4 to ensure that the appropriate signal is being monitored at the STOW limit.

**VF:** When the elevation stow switch is first encountered, the limit display will indicate “stow” vs. “STOW”. The display will change to “STOW” when either the stow current limit has been reached or the stow timeout value (15 seconds) has expired. **NOTE:** after reaching STOW, elevation must be driven above the stow limit switch to reinitialize the stow timeout.

### 3.2.2.2 Stow

As part of the STOW sequence the polarization axis will be driven to the polarization CCW limit when a linear feed is attached. If the polarization axis is not at the CCW limit, elevation movement below the DOWN limit will not be allowed.

**VF:** after sensing the elevation stow limit switch, monitoring of the elevation drive current will begin. When the elevation drive current reaches the value specified by the STW\_AMP configuration item (3.3.1.3.10), the stow operation will stop. This current monitoring is intended to allow the antenna to be “loaded” firmly into the elevation stow pads.

**VF:** the stow operation will also cease if a timeout value is reached after the stow switch is sensed but before the current limit is sensed. This timeout condition is provided as a backup to the current sensing mechanism.

### 3.3.1.3.4 Azimuth Drive Monitoring

### 3.3.1.3.7 Elevation Drive Monitoring

The items on the Drive Monitoring screens are actually used to tune drive movements based on resolver “counts”. The resolver counts are used in the same fashion as pulse counts are used for making precise movements of the mount.

### 3.3.1.3.10 Stow & Deploy Postions (VF only)

**STW\_AMP:                    ELEV STOW CURRENT LIMIT <0.0-4.9 AMPS>**

For the VF version, the amount of elevation drive current used to “preload” the antenna into its stow pads may be specified.

This configuration replaces the EL\_TIME item normally shown in this screen.

### 3.3.1.3.14 Auxiliary Down Region

The AUX DOWN configuration screen allows the values for aux\_down\_ccw, aux\_down\_cw and aux\_down as discussed in section 2.3.3 to be entered.

CCW: 32768	CONFIG-AUX DOWN
CW: 32768	
DOWN: 100	
AUX CCW RESOLVER COUNT <100 - 65535>	

### 3.3.2.5 Limits Maintenance

```

AZIM CW:0  CCW:1  STOW:0          LIMITS
ELEV UP:1  DN:1  STOW:1  f:1  E:1  ACTIVE
POL  CW:0  CCW:1  STOW:1  j:0  R:0
<BKSP>MAKE LIMITS INACTIVE  <MODE>EXIT

```

**f:1 E:1**

**j:0 R:0**

The state of the feed type inputs is also shown. The letters f, j, E and R correspond to corresponding pin in the connector. A 1 indicates that a switch closure is sensed at the pin. Note that E actually represents a logical OR'ing of pins E and D. The following table shows how the feed input combinations are interpreted.

Pin f	Pin j	Pin E	Pin R	Sensed Feed Type
0	0	0	1	C-Band Linear
0	0	1	0	C-Band Circular
0	1	0	0	X-Band Circular
0	1	0	1	Ku-Band Linear
1	1	0	0	Ka-Band Circular
1	1	0	1	Ka-Band Linear
All other combinations				INVALID FEED TYPE

### 3.3.1.2 Reset Defaults

The following table supplies the default configuration item values for this mount. Space has also been provided to record installation specific changes to the configuration items. Note: recording of installation specific changes to defaults may prove valuable when trying to restore system configuration.

CONFIGURATION ITEM	VE	VF				INSTALL VALUE
<b>SYSTEM DEFINITION</b>						
Antenna_size_cm	240	240				
GPS	1	1				
COMP	2	2				
Compass Type	1	1				
MODE	2	2				
WAVE	0	0				
<b>ELEVATION CALIBRATION</b>						
Zero Voltage	0.81	0.81				
Elev_offset	0.0	0.0				
Up_elev_limit	90	90				
Down_elev_limit	5	5				
Elevation_Scale_Factor	50.00	50.00				
Elevation_look_configuration	1	1				
Res	-164.00	-164.00				
Rev	0	0				
<b>AZIMUTH CALIBRATION</b>						
Reference_voltage	N/A	N/A				
Azim_Scale_Factor	N/A	N/A				
Fluxgate_offset	0.0	0.0				
ccw_azim_limit	150	150				
Cw_azim_limit	150	150				
Res	-180.00	-180.00				
Rev	0	0				
<b>POLARIZATION CAL</b>						
Zero Voltage	2.50	2.50				
Polarization_Offset	0.0	0.0				
CW Polarization Limit	90.0	90.0				
CCW Polarization Limit	90.0	90.0				
Pol_Scale_Factor	40.90	40.90				
Polarization_type	2	2				
H/V_Reference	0	0				
Default Horizontal Position	-45.0	-45.0				
Default Vertical Position	45.0	45.0				
Pol_Automove_Enable	1	1				
<b>SIGNAL PARAMETERS</b>						
RF_Lock	0	0				
RF_Time	0.1	0.1				
Channel 1 Polarity	1	1				
Channel 1 Threshold	100	100				
Channel 1 Delay	0.1	0.1				
Channel 1 Lock Type	0	0				
Channel 2 Polarity	1	1				
Channel 2 Threshold	100	100				
Channel 2 Delay	0.1	0.1				
Channel 2 Lock Type	0	0				

CONFIGURATION ITEM	VE	VF				INSTALL VALUE
<b>AUTOPEAK</b>						
Autopeak Enabled	0	0				
Signal Source	1	1				
RF Band	1	1				
Spiral Search AZ Limit	5	5				
Spiral Search EL Limit	5	5				
Spiral Signal Threshold	200	200				
Scan Range Limit	4	4				
Scan Signal Threshold	200	200				
<b>AZIMUTH POT DRIVE</b>						
Fast/Slow Threshold	0.5	0.5				
Maximum Position Error	0.05	0.05				
Coast Threshold	0.2	0.2				
Maximum Retry Count	3	3				
<b>AZIMUTH PULSE DRIVE</b>						
Pulse Scale Factor	10431	10431				
CW Pulse Limit	61000	61000				
CCW Pulse Limit	5000	5000				
Fast/Slow Threshold	100	100				
Maximum Position Error	2	2				
Coast Threshold	3	3				
Maximum Retry Count	2	2				
<b>AZIM DRIVE MONITORING</b>						
Jam Slop	1	1				
Runaway Slop	200	200				
Fast Deadband	1000	1000				
Slow Deadband	500	500				
<b>ELEV POT DRIVE</b>						
Fast/Slow Threshold	1.0	1.0				
Maximum Position Error	0.2	0.2				
Coast Threshold	0.4	0.4				
Maximum Retry Count	3	3				
<b>ELEV PULSE DRIVE</b>						
Pulse Scale Factor	10431	10431				
UP Pulse Limit	46000	46000				
Down Pulse Limit	1000	1000				
Fast/Slow Threshold	100	100				
Maximum Position Error	1	1				
Coast Threshold	3	3				
Maximum Retry Count	2	2				
<b>ELEV DRIVE MONITORING</b>						
Jam Slop	1	1				
Runaway Slop	200	200				
Fast Deadband	1000	1000				
Slow Deadband	500	500				

CONFIGURATION ITEM	VE	VF				INSTALL VALUE
<b>POL POT DRIVE</b>						
Fast/Slow Threshold	2.0	2.0				
Maximum Position Error	0.5	0.5				
Coast Threshold	0.3	0.3				
Maximum Retry Count	3	3				
<b>POL DRIVE MONITORING</b>						
Jam Slop	1	1				
Runaway Slop	200	200				
Fast Deadband	1000	1000				
Slow Deadband	500	500				
<b>TRACK</b>						
Search Enable	0	0				
Max Track Error	3	3				
Search Width	4	4				
Peakup Holdoff Time	120	120				
Track Signal Source	2	2				
Signal Sample Time	2	2				
<b>REMOTE CONTROL</b>						
Remote Enabled	1	1				
Bus Address	50	50				
Baud Rate	6	6				
Jog	20	20				
<b>STOW / DEPLOY</b>						
AZ STOW	0.0	0.0				
EL STOW	-75.0	-75.0				
PL STOW	-95.0	-95.0				
AZ DEPLOY	0.0	0.0				
EL DEPLOY	16.0	16.0				
PL DEPLOY	0.0	0.0				
PL ENABLED	3	3				
EL_TIME	0	N/A				
STW_AMP	N/A	1.0				
<b>AUXILIARY DOWN</b>						
AUX DOWN CCW	32768	32768				
AUX DOWN CW	32768	32768				
AUX DOWN	100	100				

4.2 Schematics

- Backpanel Interconnects



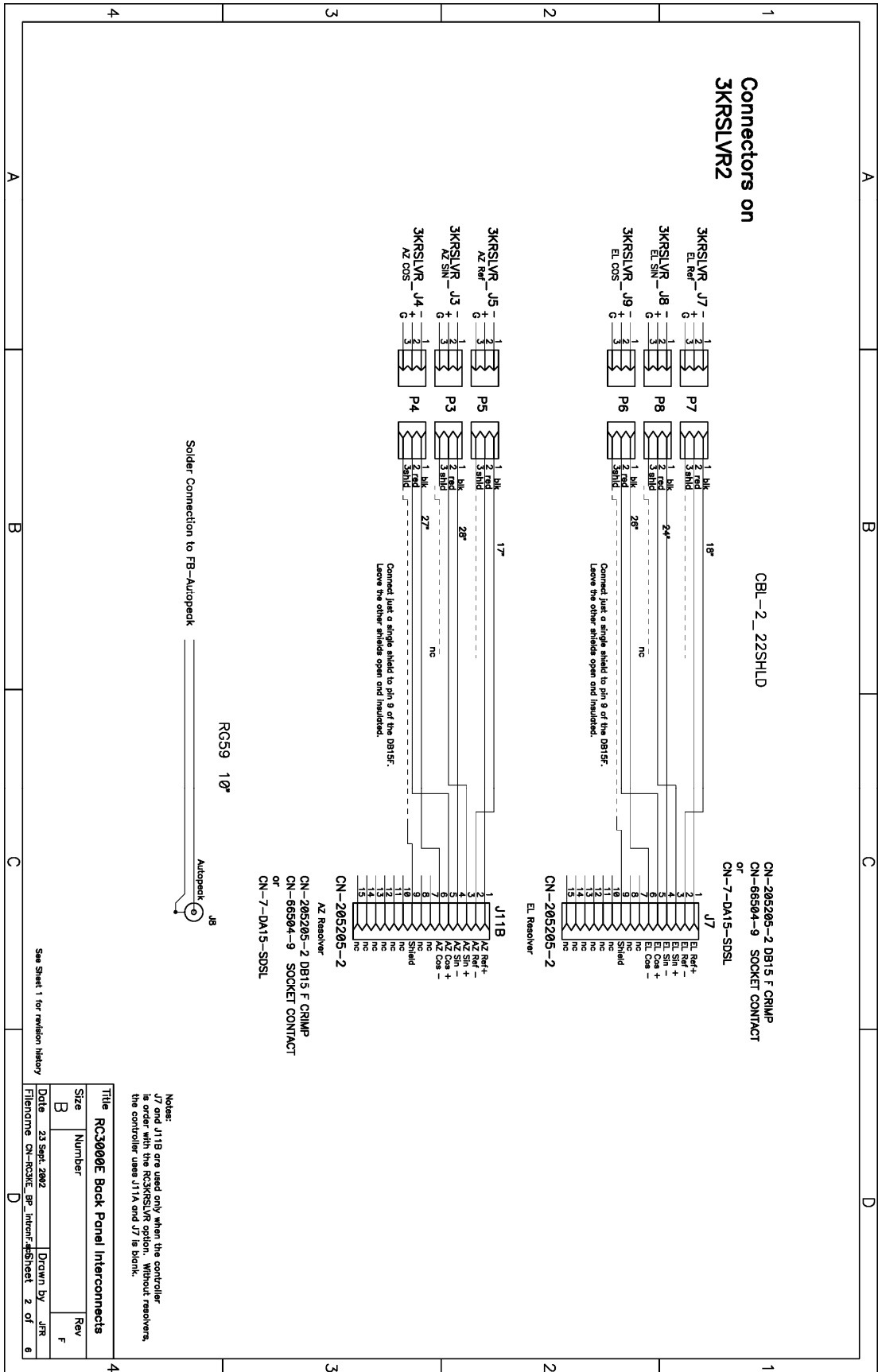

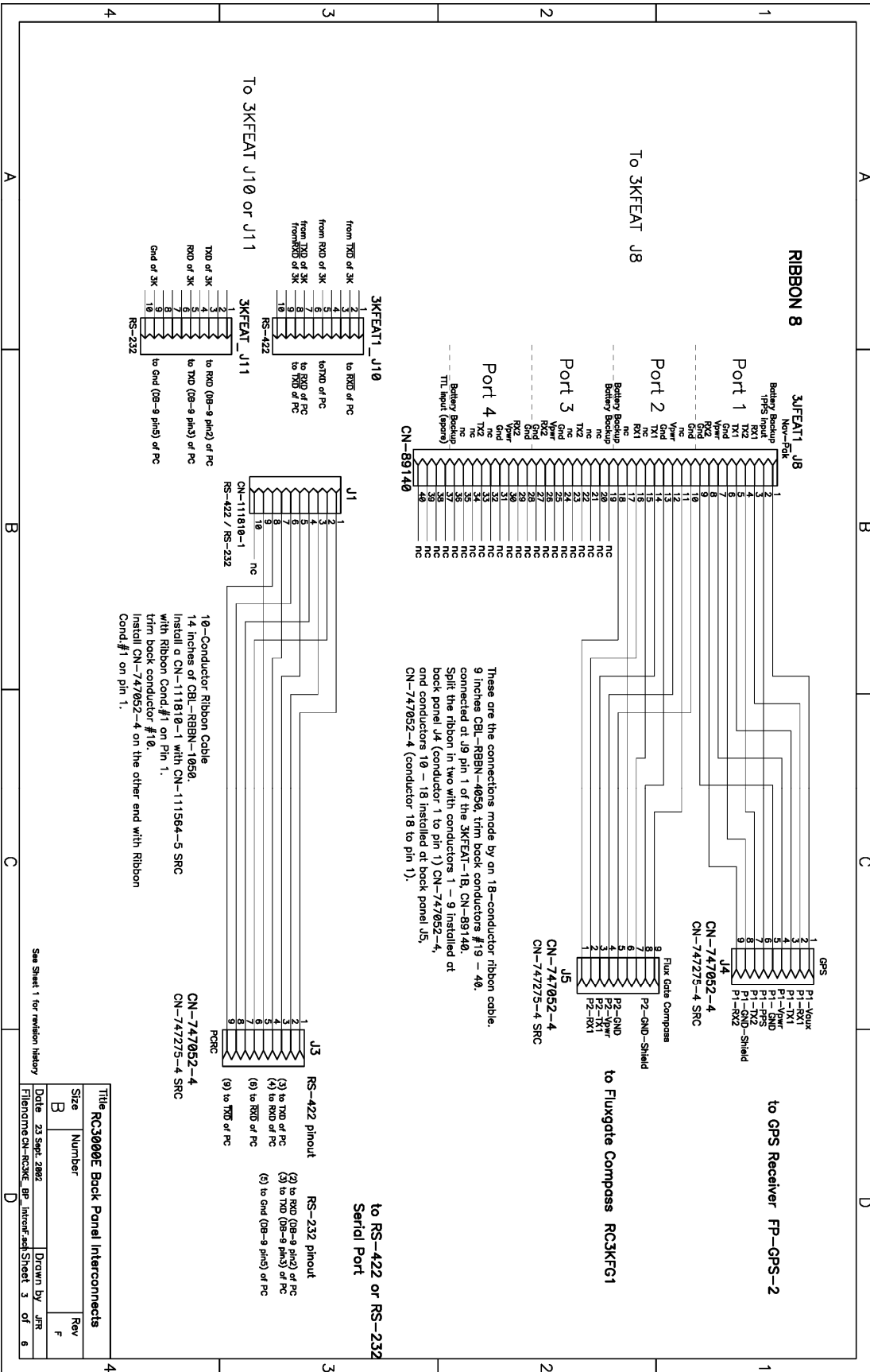

See Sheet 1 for revision history

Title			
RC3000E Back Panel Interconnects			
Size	Number	Drawn by	Rev
B		JRR	F
Date	23 Sept 2002	Drawn by	JRR
Filename	DN-RC3000E_BP_Instromt_and_Sheet_3	of	6

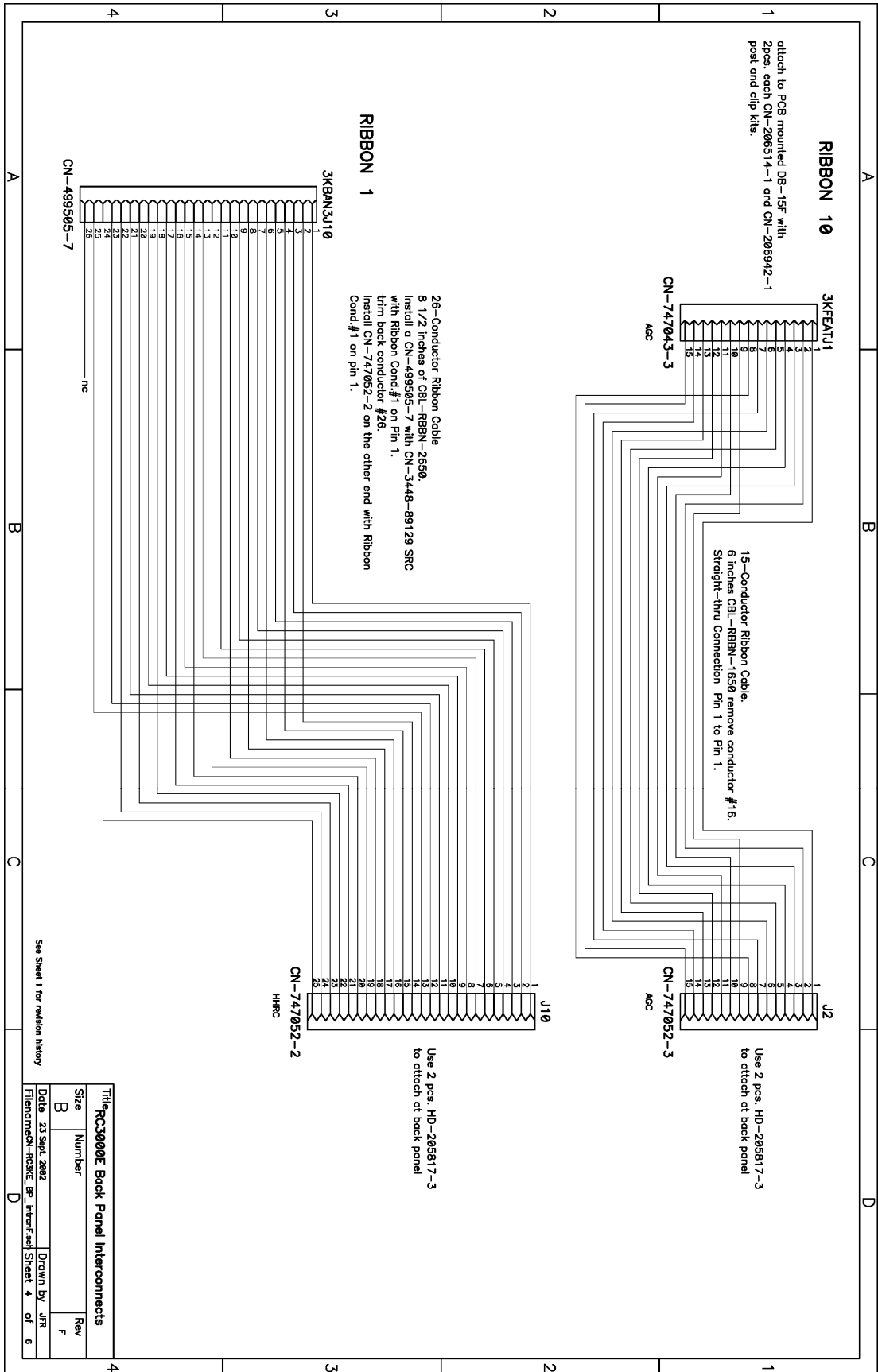

Title RC3000E Back Panel Interconnects

Size B Number

Rev F

Date 23 Sept 2002 Drawn by JRF

File: rcmch-rc3000\_e-Interf-ack Sheet 4 of 6

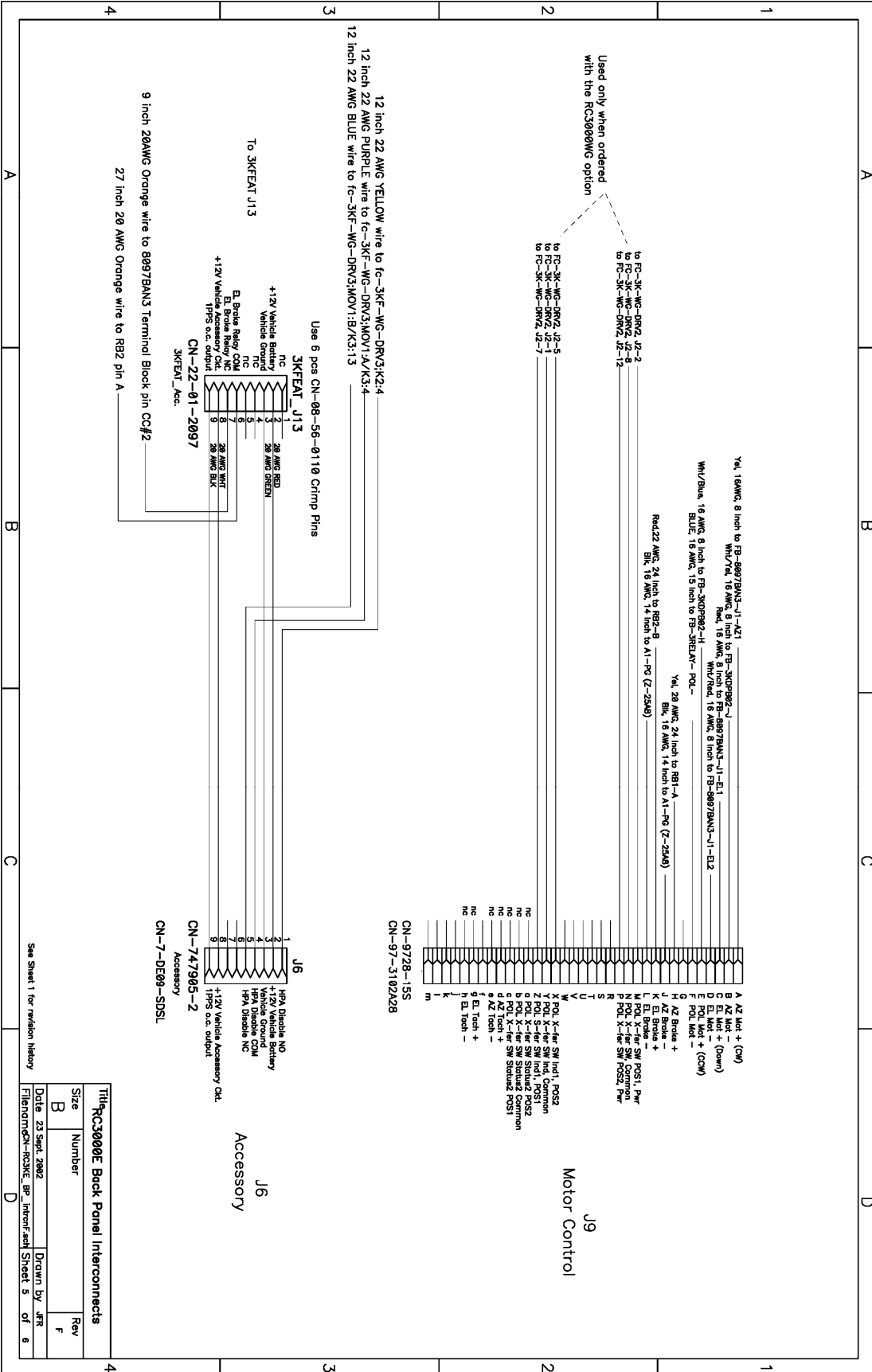

See Sheet 1 for revision history

Title		RC3000E Back Panel Interconnects	
Size	Number	Rev	
B		F	

Date: 23 Sept. 2002  
 Drawn by: JRF  
 File: rc3000-rc30c\_bp\_interf.acd  
 Sheet 5 of 8

