

APPENDIX B - MOUNT SPECIFIC DATA

For

Andrew 2.4 SNG

(RC3000F)

This appendix describes RC3000 functions unique for the Andrew 2.4 SNG mount.

Revision History. Date: 13 February 2003 - Software Version: 1.40

1.1 Manual Organization

This appendix is provided as a supplement to the baseline RC3000 manual. Differences between this version and the operation described in the baseline RC3000 manual are noted on a paragraph by paragraph basis.

1.2 RC3000 Features

All RC3000 features described in the baseline manual are present with this version. The unique features of this version of the RC3000 are:

- 1) The backpanel connectors are different from the baseline RC3000 connectors. These connectors allow use of standard Andrew interface cables.
- 2) The RC3000F drives brakes for the azimuth and elevation axis.
- 3) Azimuth, elevation and polarization position is sensed via resolvers rather than potentiometers.

Hardware Configuration. This version of the RC3000 will be referred to as an "F" model. Internally this version is similar to an "A" version (low voltage DC motor control), but the backpanel of the chassis has been modified to connect directly to Andrew 2.4 SNG wiring.

Software Configuration. The model number for this version is **N4**.

1.3.1 Controller Description

In addition to the RC3000 components described in the baseline manual, the RC3000F includes a resolver interface board and power resistors for energizing the azimuth and elevation brakes.

A high level system interconnect drawing of the RC3000F is provided in section 4.3 (schematics).

1.3.2 System Interface Requirements

The following unique interface requirements are present for the RC3000F:

- 1) Resolver inputs for azimuth, elevation and polarization position sensing.
- 2) The RC3000F provides relays to energize the azimuth and elevation brakes.
- 3) azimuth stow and elevation stow, down and up limit switches do not exist

1.3.3 Operational Overview

Operation of the N4 versions is almost identical to that described in the baseline manual. Differences will be noted in the appropriate paragraphs.

1.3.7 Drive System

Position Sensing and Limits. Azimuth stow and elevation stow, down and up limits are implemented via software (no limit switches exist). An elevation synchronization switch is sensed to switch the drive to slow (creep mode) speed several degrees before reaching the elevation stow position.

Jam and Runaway Sensing. Jammed and runaway sensing is based on resolver counts.

2.0 INSTALLATION

2.1.1 RC3000 Antenna Controller

The RC3000F is slightly deeper (19.1" vs. 17.05") than the baseline RC3000. This additional depth is required to accommodate the backpanel with Andrew connectors.

2.1.4 Electronic Clinometer

The inclinometer should be rigged with the backstructure vertical. With the backstructure vertical, the inclinometer should be mounted so that it is 12.7 (35.0 –22.3) degrees from vertical. This orientation will allow linear output from the inclinometer to a RF angle of 90 degrees.

2.2 Electrical Connections.

The RC3000F's backpanel contains the standard connectors for use with the Andrew 2.4 SNG's cabling. The following diagram shows this backpanel.

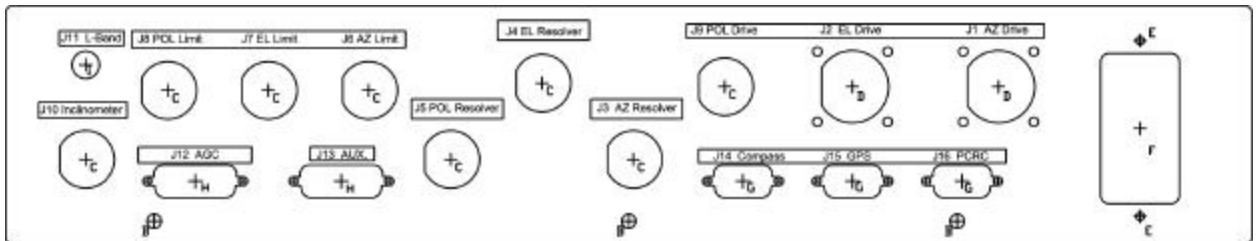

2.2.1 Power Entry

The RC3000F has the same fuse requirements as the RC3000A model (8 A. for 115, 4 A. for 230).

2.2.2 Motor Drive

2.2.3 Drive Sense

2.2.4 Limit Switches

Internal to the RC3000F is cabling that adapts the standard interface connections shown in the baseline manual to the Andrew style connectors on the backpanel. Schematics are provided in section 4.3 showing this adaptation.

Pinouts for the individual Andrew connectors are shown in the following diagrams.

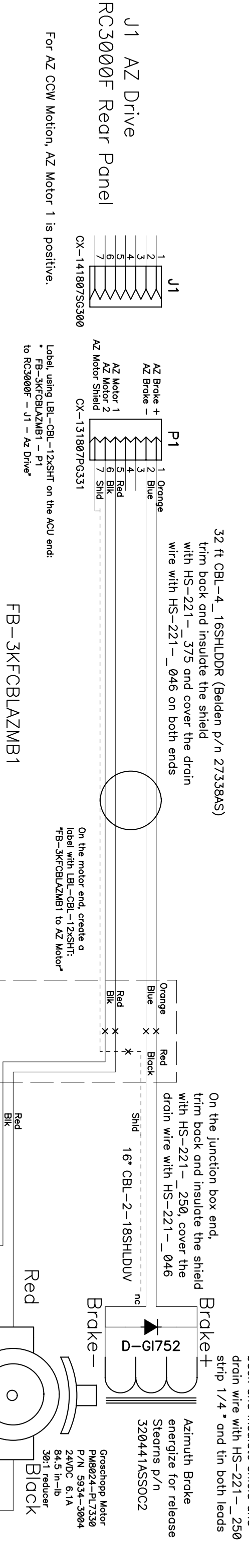
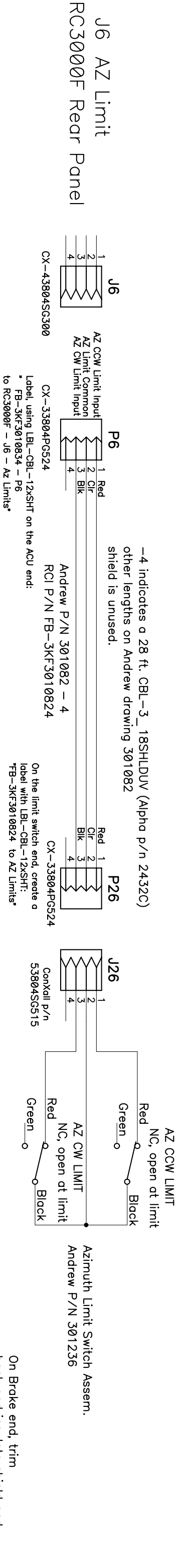
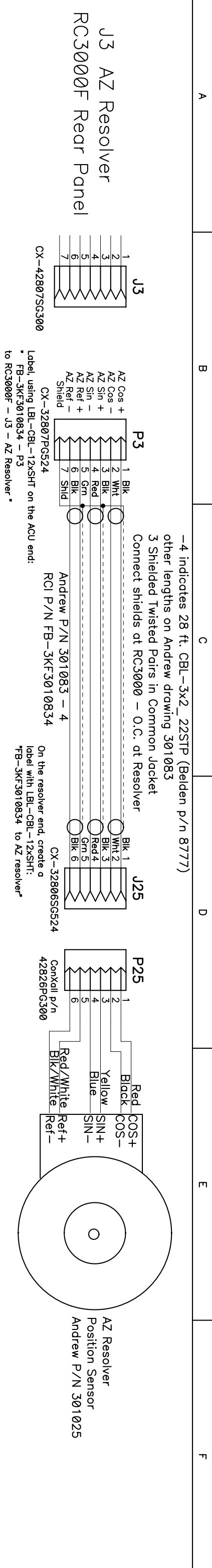

Notes:
 All connectors are from ConXall.
 Check ConXall literature for pin numbering configuration.
 the "RC3000F-Andrew 2.4m Mobile Mount Interconnect Cabling Schedule" document provides the mfg p/n's for jacketed cabling and conXall connectors.

REVISION HISTORY:
 Rev A released 26 June 2002 JFR
 Rev B Changed part numbers to follow production, added more labling, converted Motor/Brake Cabling to single cable, added buck diodes to brakes. additional notes

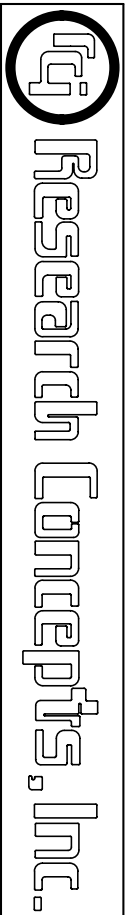

Title
 ESA24SNG-LTE Project

Size	Number	Rev
B	Andrew ESA24SNG-LTE Cabling	B
Date	1 December 2002	Drawn by JFR
Filename	ESA24SNGLTIB.sch	Sheet 1 of 3

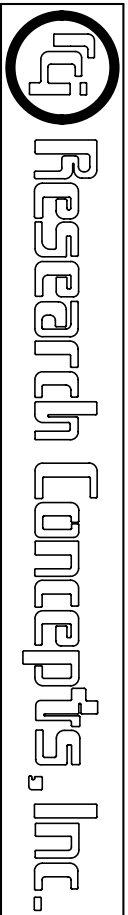
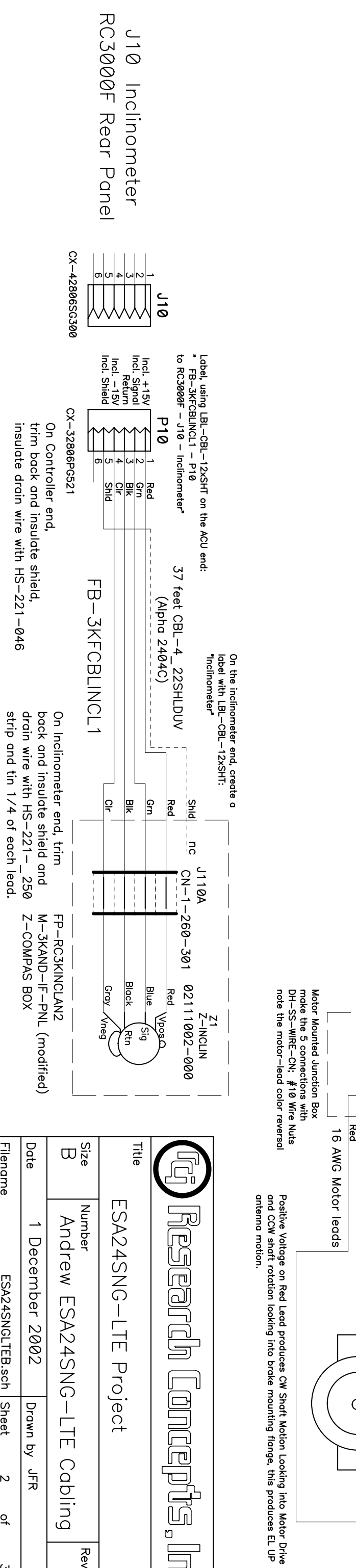
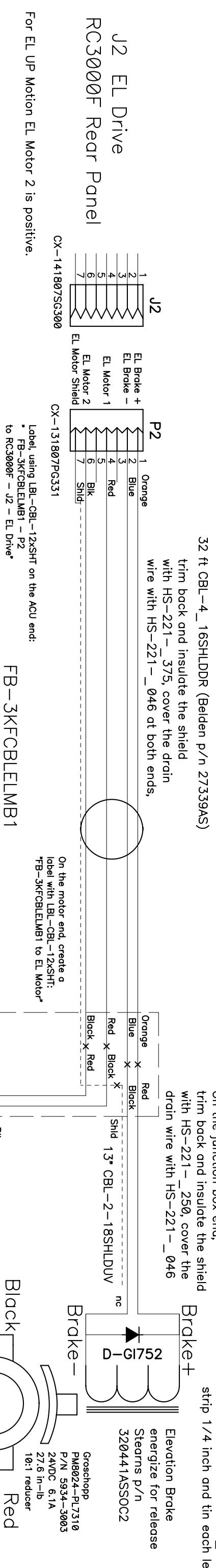
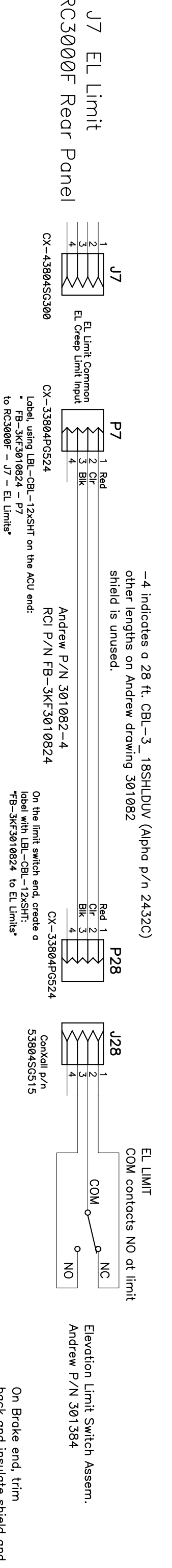
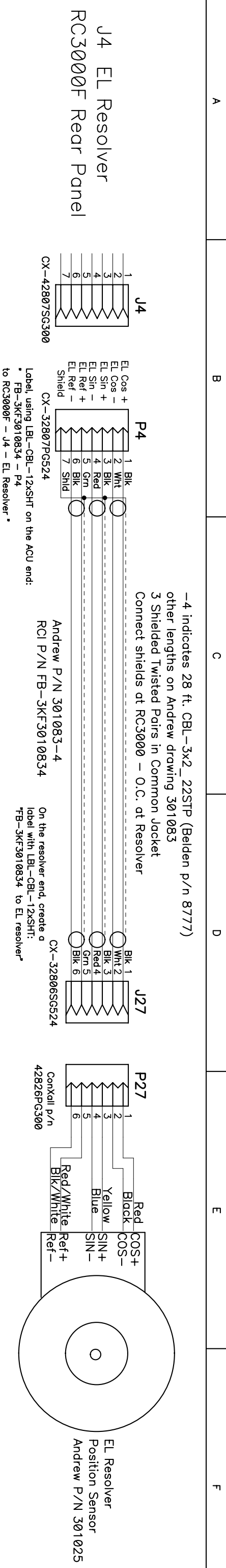

ESA24SNG-LTE Project

Title	ESA24SNG-LTE Project	
Size	Number	Rev
B	Andrew ESA24SNG-LTE Cabling	B
Date	1 December 2002	Drawn by JFR
Filename	ESA24SNGLTB.sch	Sheet 2 of 3

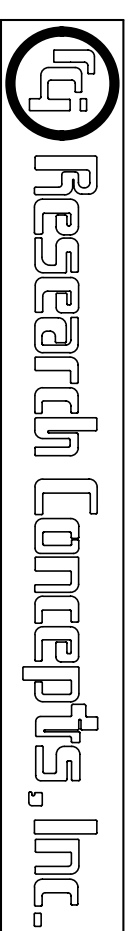
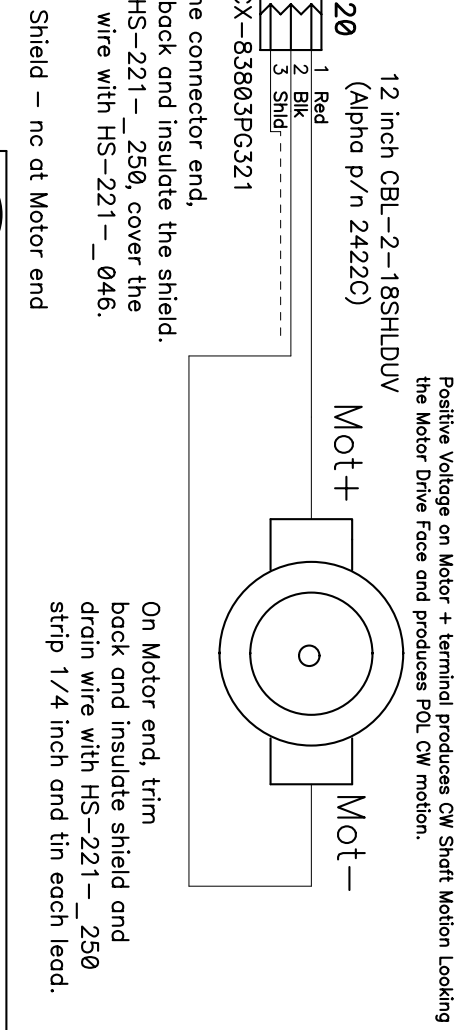
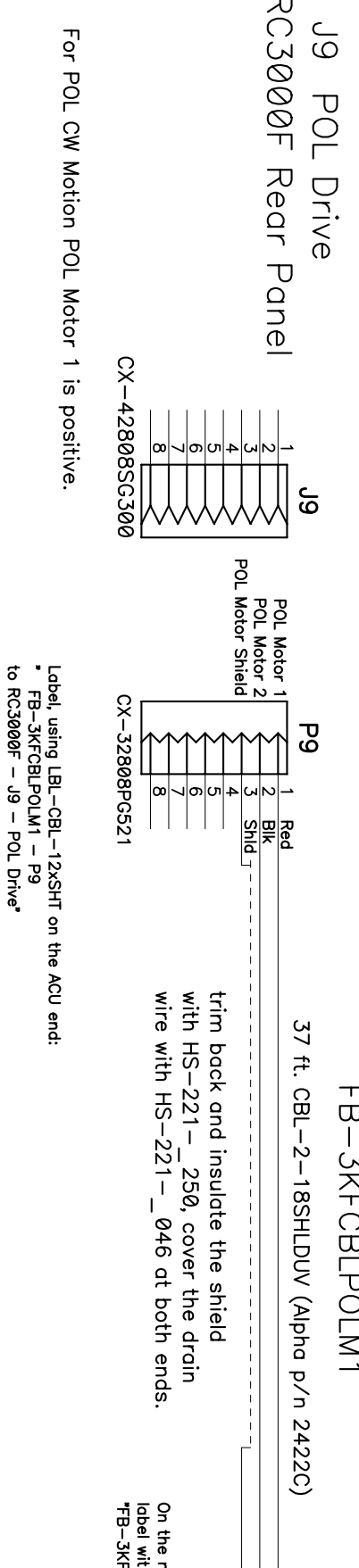
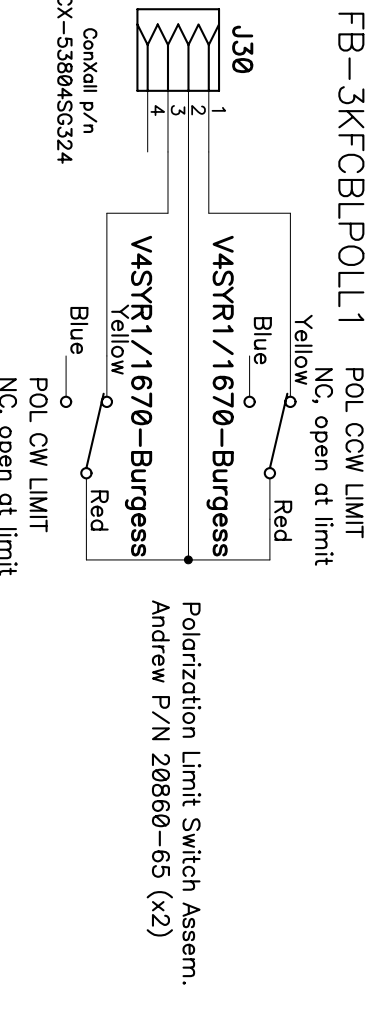
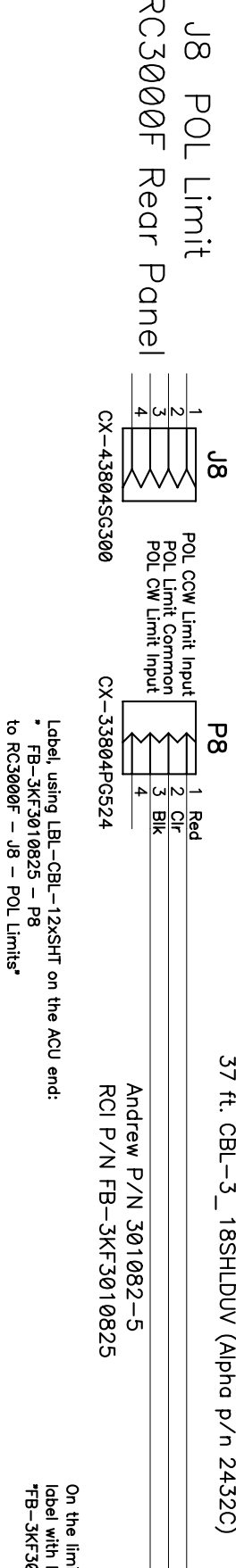
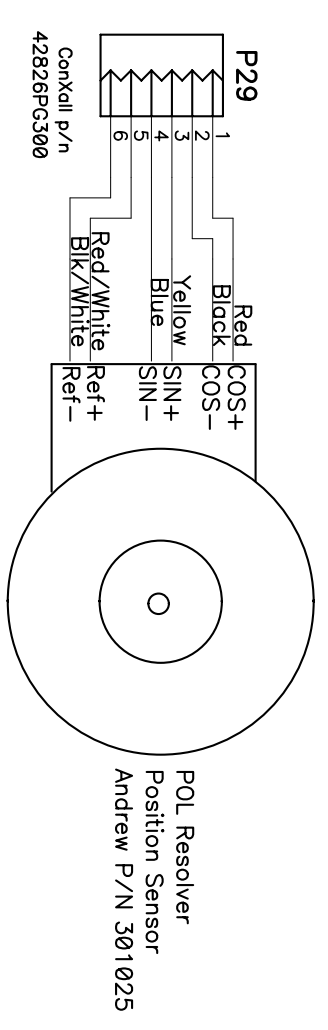
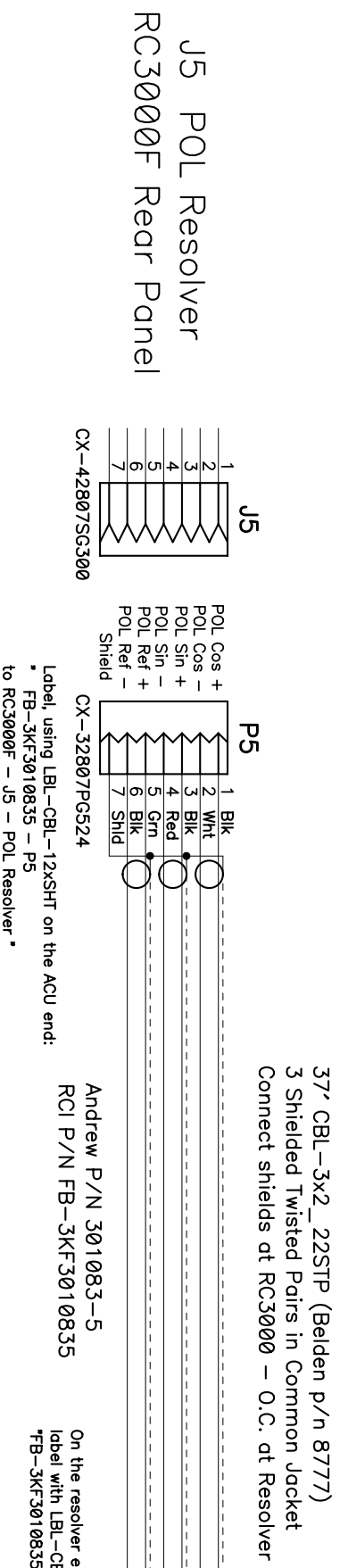

Title
ESA24SNG-LTE Project

Size	Number	Rev
B	Andrew ESA24SNG-LTE Cabling	B

Date	1 December 2002	Drawn by	JFR
Filename	ESA24SNGLTIB.sch	Sheet	3 of 3

The following connectors are provided on the backpanel of the RC3000F. Their pin assignments and function is as described in the baseline manual.

2.2.5 Signal Strength

This connector is designated J12 on the 3000F backpanel.

NOTE: The gain and offset potentiometers associated with the signal strength connector are recessed from the backpanel on the RC3000F model. The lid of the RC3000 will have to be removed in order to calibrate these pots.

2.2.6 Navigation Sensors

On “baseline” RC3000’s the J9 connector is a 37 pin connector. An adapter “dongle” is supplied that adapts the DB-37 to two DB-9 connectors.

The RC3000F model supplies the two DB-9 connectors (J14-Fluxgate, J15-GPS) directly on the backpanel. Pinouts for these DB-9s are as shown in the baseline manual.

2.2.7 Accessories

This connector is designated as J13 on the RC3000F backpanel.

2.2.8 RF Autopeak

This connector is designated as J11 on the RC3000F backpanel.

2.2.9 Hand Held Remote

The handheld remote control option is not supported on the RC3000F.

2.2.11 PC Remote Control

This connector is designated as J16 on the RC3000F backpanel.

2.3 Calibration

While similar in scope, the calibration steps for the RC3000F are quite different from the procedure described in the baseline manual. These differences arise mainly due to the fact that the RC3000F interfaces to resolvers and that the elevation STOW, DOWN and UP limits are defined by resolver values rather than limit switches.

The calibration steps are defined in the following table.

#	STEP	ACTION
1	Inactivate Software Limits	MAINTENANCE MENU - LIMITS Press BKSP to inactivate software limits *** WARNING - LIMITS INACTIVE *** alarm will flash on line 4
2	Carefully move the mount to STOW position	MANUAL mode Use EL UP/DOWN, AZ CW/CCW to jog mount
3	Define Azimuth Reference Position Verify that mount is in exact center of azimuth travel (STOW position) NOTE: azimuth resolver should be rigged to approximately the 180 degree position	MAINTENANCE MENU - VOLTS Record raw azimuth resolver angle _____ AZIMUTH CALIBRATION Configuration Screen RES: enter angle required to obtain 0.0 from raw azimuth resolver angle. MANUAL: Confirm that AZIM: value is 0.0
4	Define Software Azimuth Stow Switch	MANUAL mode Press SCR UP to display azimuth resolver count value _____ AZIMUTH PULSE DRIVE Configuration Screen Enter recorded resolver count value in STOW: field
5	Define Elevation Inclinator Reference Position Raise reflector to the "face vertical" position NOTES: - this step should be accomplished with the mount's platform level so that the elevation angle derived from the inclinometer and the resolver are the same.	MAINTENANCE MENU - VOLTS Record elevation input voltage _____ NOTE: a correctly oriented inclinometer should yield a voltage of 1.89 +/- 0.2 VDC. Reorient the inclinometer if the voltage falls out of this range. ELEVATION CALIBRATION Configuration Screen REF_V: Enter recorded voltage MANUAL mode: Confirm that ELEV: value is 22.3 +/- 0.2

<p>6</p>	<p>Define Elevation Resolver Reference Position</p> <p>Performed from same position as in the last step</p> <p>- at this position the elevation resolver should be rigged to approximately 180 degrees</p>	<p>MAINTENANCE MENU - VOLTS</p> <p>Record raw elevation resolver angle _____</p> <p>ELEVATION CALIBRATION</p> <p>Configuration Screen:</p> <p>RES: enter angle required to obtain 22.3 from raw elevation resolver angle.</p> <p>MAINTENANCE MENU - VOLTS</p> <p>Confirm that resultant elevation angle is 22.3</p>
<p>7</p>	<p>Determine Electronic Inclinator Scale Factor</p> <p>After recording values at the elevation reference position, the mount will be raised approximately 40 degrees in elevation to characterize the scale factor for the installed elevation inclinometer</p>	<p>Before moving from reference position place accurate level on backstructure and record angle _____</p> <p>MAINTENANCE MENU - VOLTS</p> <p>Record elevation input voltage _____</p> <p>MANUAL: Move UP approximately 40 degrees and place accurate level on backstructure and record angle _____</p> <p>MAINTENANCE MENU - VOLTS</p> <p>Record elevation input voltage _____</p> <p>Calculate elevation scale factor as discussed in section 2.3.2 of the RC3000 User's Manual</p> <p>ELEVATION CALIBRATION</p> <p>Configuration Screen: Enter calculated scale factor (mV/deg.) in SF: field</p> <p>MANUAL mode: Confirm that ELEV reads 22.3 + number of degrees physically_rotated</p>
<p>8</p>	<p>Define Elevation UP Software Limit</p> <p>Move elevation axis to desired UP limit</p>	<p>MANUAL MODE:</p> <p>SCR UP to display and record ELEV: resolver count _____</p> <p>ELEVATION PULSE Configuration Screen:</p> <p>Enter recorded resolver count in UP: field*</p> <p>* - entry may be delayed until step # 11</p>
<p>9</p>	<p>Define Elevation DOWN Limit</p> <p>Move elevation axis to desired DOWN limit</p> <p>Typically set around 5.0 degrees or required position to avoid obstacles while moving in azimuth.</p>	<p>MANUAL MODE:</p> <p>SCR UP to display and record ELEV: resolver count _____</p> <p>ELEVATION PULSE Config Screen:</p> <p>Enter recorded resolver count in DOWN: field*</p>

10	<p>Define Elevation Sync Software Limit</p> <p>Move elevation axis to position where sync (creep) switch activates</p>	<p>MANUAL MODE: Synch (creep) switch is displayed by the ":" following ELEV changing to "." SCR UP to display and record ELEV: resolver count _____ ELEVATION PULSE Configuration Screen: Enter recorded resolver count in SYNC: field*</p>
11	<p>Define Elevation STOW Software Limit</p> <p>Move elevation axis to desired STOW limit</p>	<p>MANUAL MODE: SCR UP to display and record ELEV: resolver count _____ ELEVATION PULSE Configuration Screen: Enter recorded resolver count in STOW: field</p>
12	<p>Define Polarization Reference Position</p> <p>Move polarization axis to the position where the feed is horizontal/vertical (nearest to center of travel). This position is approximately where the center feed set screw is horizontal. - at this position the polarization resolver should be rigged to approximately 180 degrees</p>	<p>MAINTENANCE MENU - VOLTS Record raw polarization resolver angle _____ POLARIZATION CALIBRATION Configuration Screen RES: enter angle required to obtain 0.0 from raw polarization resolver angle. MANUAL Confirm that POL: value is 0.0</p>
13	<p>Confirm Polarization CW, CCW limits</p> <p>Move to CW and CCW limits</p>	<p>MANUAL MODE: Confirm that "CW" and "CCW" limits are displayed</p>
14	<p>Define Azimuth Clockwise Software Limit</p> <p>Move azimuth axis to clockwise limit</p>	<p>MANUAL MODE: Confirm that "CW" limit is triggered via limit switch SCR UP to display and record AZIM: resolver count _____ AZIMUTH PULSE Configuration Screen: Enter recorded resolver count in CW: field</p>
15	<p>Define Azimuth Counter-Clockwise Software Limit</p> <p>Move azimuth axis to counter-clockwise limit</p>	<p>MANUAL MODE: Confirm that "CCW" limit is triggered via limit switch SCR UP to display and record AZIM: resolver count _____ AZIMUTH PULSE Configuration Screen: Enter recorded resolver count in CCW: field</p>
16	<p>Activate Software Limits</p>	<p>MAINTENANCE MENU - LIMITS Press BKSP to activate limits Alarm on line 4 will disappear</p>

17	Confirm all limit switch actions and indications Move azimuth, elevation and polarization axes through their entire range of movement.	MANUAL MODE: Verify sanity of all angle and limit indications
----	---	---

3.2.1 Manual Mode.

As an aid in calibration, the state of the elevation synch switch is displayed next to the elevation limit field. When the synch switch is activated "ELEV." appears instead of the normal "ELEV:".

```

AZIM:  0.0 STOW   SS1: 50           MANUAL
ELEV. -42.5 DOWN  SAT:TELSTAR 402
POL:   30.0 V     SPD:FAST         CST
<0-9>JOG ANTENNA <MODE>MENU      14:25:47
```

Note also that when the elevation axis is below the DOWN limit position the displayed elevation angle is derived from the elevation resolver rather than the electronic inclinometer.

3.2.2 Menu Mode

Note that when the "SYNC LIMIT ERROR" (see 3.4) is active, no automatic movements are allowed since the controller does not have confidence in the software limits. In this case the MENU screen will only show and allow items 7 (POSITION) and 8 (SETTINGS) to be activated.

3.3.1.2.2 Elevation Calibration

In addition to the normal inclinometer calibration items, two elevation resolver calibration items are included.

```

REF_V:1.69 OFF:  0.0           CONFIG-ELEV
DOWN:  0   UP:  90.0   SF:50.00
LOOK:1   RES: 0.0   REV:0
SET REFERENCE VOLTAGE <0.50 - 3.50>
```

RES: ELEV RESOLVER OFFSET<+/-300.00 DEGREES>

The elev_resolver_offset configuration item defines the offset to be applied to the angle read directly from the elevation resolver for the purpose of displaying elevation angle. Example: If when at the elevation reference (stow) position the raw elevation resolver angle reads 122.3, a elev_resolver_offset of -100.0 will result in a resolver based elevation angle of 22.3.

NOTE: the resolver-based angle is displayed in MANUAL mode when the elevation DOWN limit is active.

REV: ELEV RESOLVER<0-NORMAL 1-REVERSED>

The elev_resolver_reversed configuration item defines whether the polarity of the elevation resolver matches that of the RC3000 resolver circuitry. If the raw elevation resolver angle decreases as the mount moves up, the elev_resolver_reversed item must be described as reversed.

3.3.1.2.3 Azimuth Calibration

In addition to the normal azimuth calibration items, two azimuth resolver calibration items are included. No azimuth reference_voltage item is displayed since no azimuth potentiometer is present.

```

OFF: 0.0          CONFIG-AZIM
CCW:180  CW:180
RES: 0.0 REV:0
SET REFERENCE VOLTAGE <2.00 - 3.00>

```

RES: AZIM RESOLVER OFFSET<+/-300.00 DEGREES>

The azim_resolver_offset configuration item defines the offset to be applied to the angle read directly from the azimuth resolver for the purpose of displaying azimuth angle. Example: If when at the azimuth stow position the raw azimuth resolver angle reads 181.3, a azim_resolver_offset of -181.3 will result in a resolver based azimuth angle of 0.0.

REV: ELEV RESOLVER<0-NORMAL 1-REVERSED>

The elev_resolver_reversed configuration item defines whether the polarity of the elevation resolver matches that of the RC3000 resolver circuitry. If the raw elevation resolver angle decreases as the mount moves up, the elev_resolver_reversed item must be described as reversed.

3.3.1.3.2 Azimuth Pot Drive

Since no potentiometer exists on the azimuth axis, these items actually are used to tune azimuth movements based on angles derived from the resolver feedback.

3.3.1.3.3 Azimuth Pulse Drive

This screen has been modified to include definition of the azimuth stow position.

```

SCALE:10431          CONFIG-AZ PULSE
CW:65000 STOW:32768 F/S:80  COAST: 3
CCW: 100           MAX: 2  TRIES: 3
AZIM STOW PULSE LIMIT <0 -65535>

```

STOW: 32768

AZIM STOW PULSE LIMIT <0 -65535>

This fields allows the user to state (in azimuth resolver counts) the azimuth stow position.

Note that the RC3000F will display "STOW" when the azimuth axis is within +/- 1.0 degrees of this position.

3.3.1.3.4 Azimuth Drive Monitoring

3.3.1.3.7 Elevation Drive Monitoring

The items on the Drive Monitoring screens are actually used to tune drive movements based on resolver "counts". The resolver counts are used in the same fashion as pulse counts are used for making precise movements of the mount.

3.3.1.3.6 Elevation Pulse Drive

This screen has been modified to include definition of the elevation stow and sync positions.

```
SCALE:10431          CONFIG-AZ PULSE
  UP:40500 STOW:16420 F/S:100 COAST: 5
  DOWN:29600 SYNC:16500 MAX: 1 TRIES: 3
AZIM STOW PULSE LIMIT <0 -65535>
```

STOW: 32768

ELEV STOW PULSE LIMIT <0 -65535>

This fields allows the user to state (in elevation resolver counts) the elevation stow position.

STOW: 32768

ELEV SYNC PULSE LIMIT <0 -65535>

This fields allows the user to state (in elevation resolver counts) the elevation sync switch position.

3.3.2.1 Analog to Digital Voltages

In addition to the normal voltages displayed this screen also shows “raw resolver” angles and counts.

```
AZ: 1.114 181.30 33004 AD VOLTAGES
EL: 1.143 1 122.30 22264 22.3 L1:0
POL:2.237 L2:1
SIG: 3.756(1) <1>RF <2>SS1 <3>SS2 <4>GND
```

The azimuth and elevation resolver angles and counts displayed are read directly from the resolvers without being biased by offset terms. NOTE: The displayed values will reflect if the azimuth or elevation resolver polarity has been reversed.

As an aid in calibrating the elevation resolver, the angle resulting from applying offset and reverse factors is also displayed.

3.3.2.5 Limits Maintenance

```
AZIM CW:0 CCW:1 STOW:0 LIMITS
ELEV UP:1 DN:1 STOW:1 SYNC:1 ACTIVE
POL CW:0 CCW:1 STOW:1
<BKSP>MAKE LIMITS INACTIVE <MODE>EXIT
```

SYNC:1

In addition to the normal limit switch state information, this screen also shows the state of the elevation synchronization switch. The SYNC field will be 1 if the synchronization switch is active.

3.3.1.2 Reset Defaults

The table at the end of this appendix supplies the default configuration item values for this mount. Space has also been provided to record installation specific changes to the configuration items. Note: recording of installation specific changes to defaults may prove valuable when trying to restore system configuration.

3.4 Alarm Displays

The following alarms are unique to the RC3000F.

LIMITS INACTIVE!

As discussed in 3.3.6, if software limits are set inactive this alarm will be displayed.

AZIM LIMITS ERROR

If the stored value for the azimuth reference position is determined to be corrupt, this alarm is displayed.

ELEV LIMITS ERROR

If the stored value for the elevation reference position or the value for the elevation STOW, SYNCH, DOWN or UP limits is determined to be corrupt, this alarm is displayed.

SYNC LIMIT ERROR

The state of the synch limit switch is constantly checked versus the current elevation resolver value. If the state of the switch does not agree to within 1.0 degrees of the value stored for the SYNC limit, this alarm will be displayed. This alarm indicates that the controller cannot trust the resolver position and all motion will be disallowed. Software limits will need to be inactivated to allow debugging of the problem.

CONFIGURATION ITEM	N4							INSTALL VALUE
SYSTEM DEFINITION								
Antenna_size_cm	240							
GPS	2							
COMP	1							
MODE	2							
WAVE	0							
ELEVATION CALIBRATION								
Zero Voltage	1.89							
Elev_offset	0.0							
Up_elev_limit	65							
Down_elev_limit	0							
Elevation_Scale_Factor	50.00							
Elevation_look_configuration	1							
Res	-157.0							
Rev	0							
AZIMUTH CALIBRATION								
Reference_voltage	N/A							
Azim_Scale_Factor	N/A							
FG_offset	0.0							
ccw_azim_limit	175							
Cw_azim_limit	175							
Res	-180.0							
Rev	1							
POLARIZATION CAL								
Res	-180.0							
Rev	1							
CW Polarization Limit	90.0							
CCW Polarization Limit	90.0							
Pol_Scale_Factor	40.90							
Polarization_type	2							
H/V_Reference	1							
Default Horizontal Position	90.0							
Default Vertical Position	0							
Pol_Automove_Enable	1							
SIGNAL PARAMETERS								
RF_Lock	0							
RF_Time	0.1							
Channel 1 Polarity	1							
Channel 1 Threshold	100							
Channel 1 Delay	0.1							
Channel 1 Lock Type	0							
Channel 2 Polarity	1							
Channel 2 Threshold	100							
Channel 2 Delay	0.1							
Channel 2 Lock Type	0							

CONFIGURATION ITEM	N4							INSTALL VALUE
AUTOPEAK								
Autopeak Enabled	0							
Signal Source	1							
RF Band	1							
Spiral Search AZ Limit	3							
Spiral Search EL Limit	3							
Spiral Signal Threshold	200							
Scan Range Limit	8							
Scan Signal Threshold	200							
AZIMUTH POT DRIVE								
Fast/Slow Threshold	0.5							
Maximum Position Error	0.05							
Coast Threshold	0.0							
Maximum Retry Count	3							
AZIMUTH PULSE DRIVE								
Pulse Scale Factor	10431							
CW Pulse Limit	65000							
CCW Pulse Limit	100							
Stow Position	32768							
Fast/Slow Threshold	80							
Maximum Position Error	2							
Coast Threshold	3							
Maximum Retry Count	3							
AZIM DRIVE MONITORING								
Jam Slop	5							
Runaway Slop	200							
Fast Deadband	1000							
Slow Deadband	500							
ELEV POT DRIVE								
Fast/Slow Threshold	1.0							
Maximum Position Error	0.2							
Coast Threshold	0.3							
Maximum Retry Count	3							
ELEV PULSE DRIVE								
Pulse Scale Factor	10431							
UP Pulse Limit	40500							
Down Pulse Limit	29600							
Stow	16420							
Sync	16500							
Fast/Slow Threshold	100							
Maximum Position Error	1							
Coast Threshold	5							
Maximum Retry Count	3							
ELEV DRIVE MONITORING								
Jam Slop	5							
Runaway Slop	200							
Fast Deadband	1000							

CONFIGURATION ITEM	N4							INSTALL VALUE
POL POT DRIVE								
Fast/Slow Threshold	2.0							
Maximum Position Error	0.5							
Coast Threshold	0.3							
Maximum Retry Count	3							
POL DRIVE MONITORING								
Jam Slop	5							
Runaway Slop	200							
Fast Deadband	1000							
Slow Deadband	500							
TRACK								
Search Enable	0							
Max Track Error	3							
Search Width	4							
Peakup Holdoff Time	120							
Track Signal Source	2							
Signal Sample Time	2							
REMOTE CONTROL								
Remote Enabled	1							
Bus Address	50							
Baud Rate	6							
Jog	20							
STOW / DEPLOY								
AZ STOW	0.0							
EL STOW	-67.5							
PL STOW	0.0							
AZ DEPLOY	0.0							
EL DEPLOY	38.0							
PL DEPLOY	0.0							
PL ENABLED	0							

4.2 Schematics

- Internal Interconnects
- Backpanel Interconnects
- Resolver board

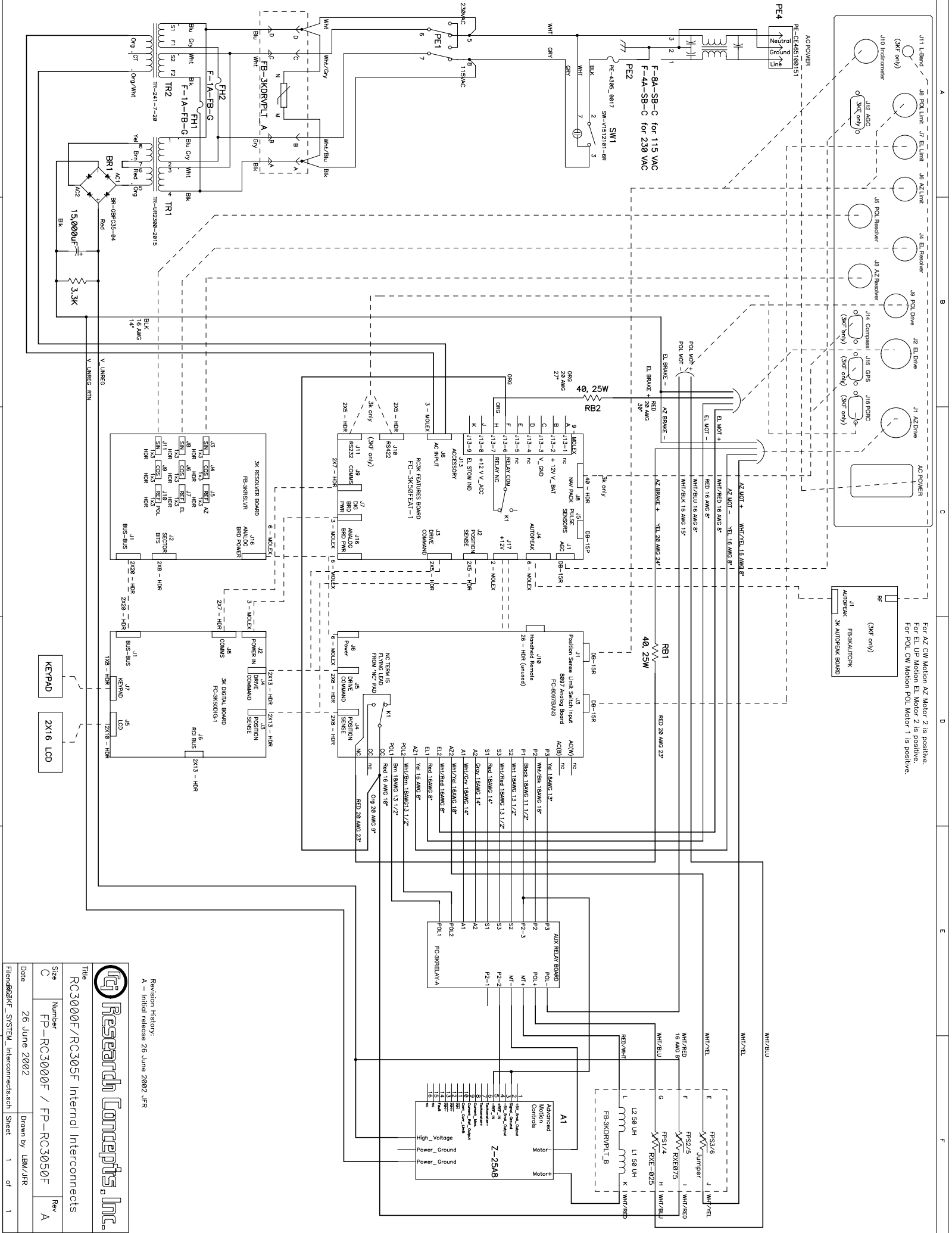

For AZ CW Motion AZ Motor 2 is positive.
 For EL Up Motion EL Motor 2 is positive.
 For POL CW Motion POL Motor 1 is positive.

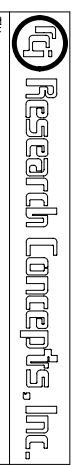

Revision History:
 A - Initial release 26 June 2002 JFR

This RC3000F/RC305F Internal Interconnects

Size	Number	Rev
C	FP-RC3000F / FP-RC3050F	A
Date	26 June 2002	Drawn by LBM/JFR

FiendR&Kf_SYSTEM_Interconnects.sch Sheet 1 of 1

attach to PCB mounted DB-15F with
 2pcs. each CN-206514-1 and CN-206942-1
 post and clip kits.

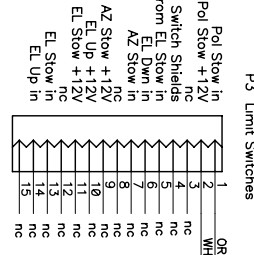

CN-747908-2 DB15 M Solderpot

To 8097BAN3 J3

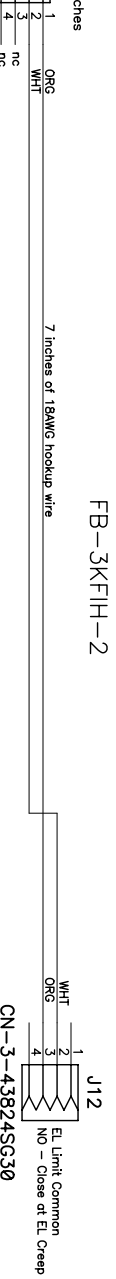

J7 EL Limit
 RC3000F Rear Panel

attach to PCB mounted DB-15F with
 2pcs. each CN-206514-1 and CN-206942-1
 post and clip kits.

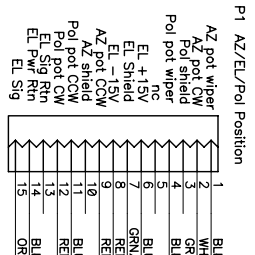

CN-747908-2 DB15 M Solderpot

To 8097BAN3 J1

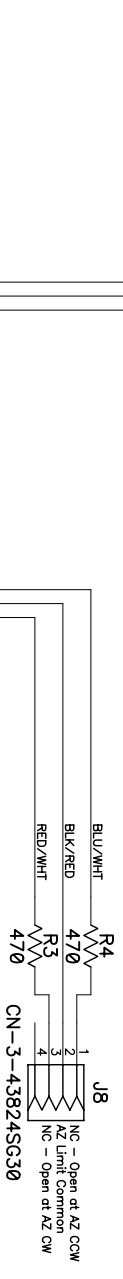

J8 POL Limit
 RC3000F Rear Panel

FB-3KFIH-3

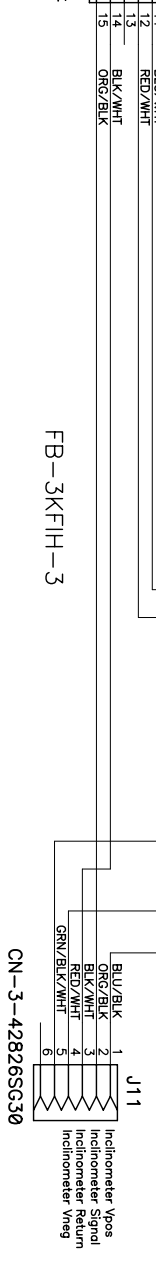

J10 Inclinator
 RC3000F Rear Panel

Notes:
 Install R1, R2, R3, R4 directly in each back panel connector pin.
 cover the entire resistor and connections with double HS.
 insulate and strengthen each connection with HS-221-125.

See Sheet 1 for revision history

Title		
RC3000F Back Panel Interconnects		
Size	Number	Rev
B	FB-3KFIH-X	A
Date	Drawn by	
26 June 2002	JFR	
File name	Sheet 2 of 5	
RC3K_F_BP_IntcrnA.sch		

A

B

C

D

1

1

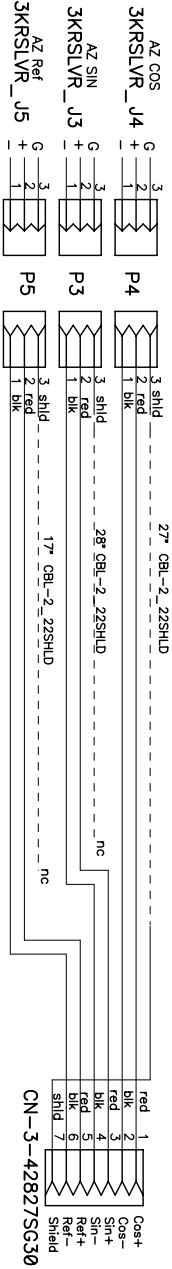

FB-3KFIH-4

2

2

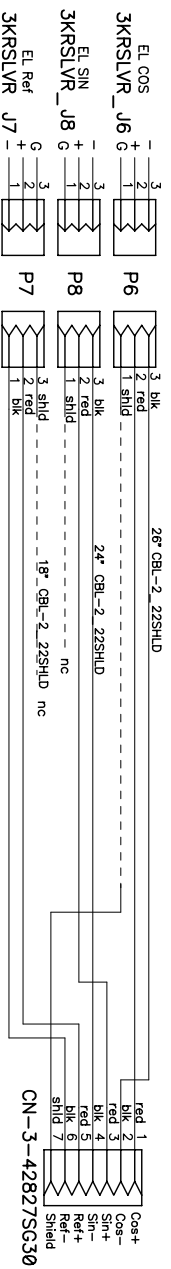

FB-3KFIH-5

Connectors on 3KRSLVR1

3

3

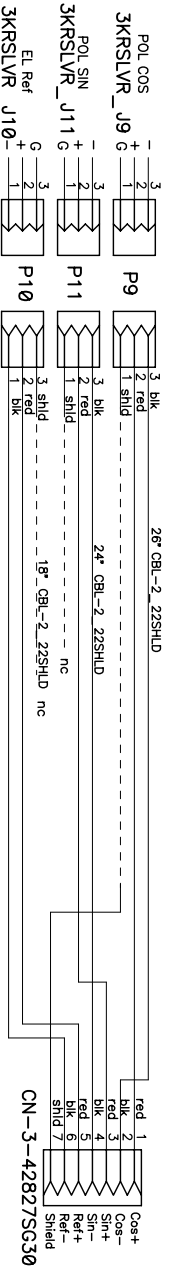

FB-3KFIH-6

A

B

C

D

4

4

Title			
RC3000F Back Panel Interconnects			
Size	Number	Rev	
B	FB-3KFIH-X	A	
Date	Drawn by		Rev
26 June 2002	JFR		5
File name		Sheet	of
RC3KF_BR_intcrk.sch		3	5

Connect just a single shield to pin 7 of J5. Leave the other shields open and insulated.
 Use HS-221-046 over the open drain wire. Individually insulate each connection with HS-221-125.
 The 3KRSLVR1 end of each of these wiring harnesses requires 3 pcs CN-22-01-2837 and 9 pcs. CN-08-56-0110 or CN-08-56-0106.

See Sheet 1 for revision history

J12 AGC Input
 RC3000F Rear Panel
 (not used on RC3050)

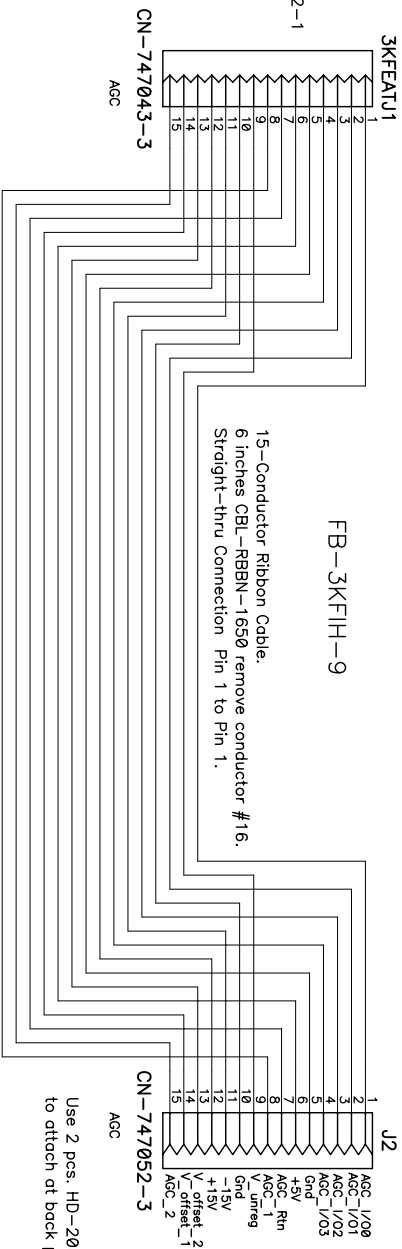

Use 2 pcs. HD-205817-3 and 2 pcs. HD-No4_LW
 to attach at back panel

attach to PCB mounted DB-15F with
 2pcs. each CN-206514-1 and CN-206942-1
 post and clip kits.

Solder Connection to FB-Autopeak
 RF Input

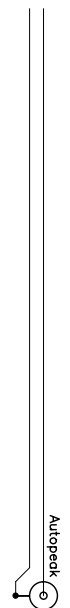

J11 L-Band Input
 RC3000F Rear Panel
 (not used on RC3050)

Title RC3000F Back Panel Interconnects			
Size B	Number FB-3KFIH-X	Rev A	
Date 26 June 2002	Drawn by JFR	Sheet 5	of 5
Filename: RC3KF_BP_intcon.sch			

See Sheet 1 for revision history

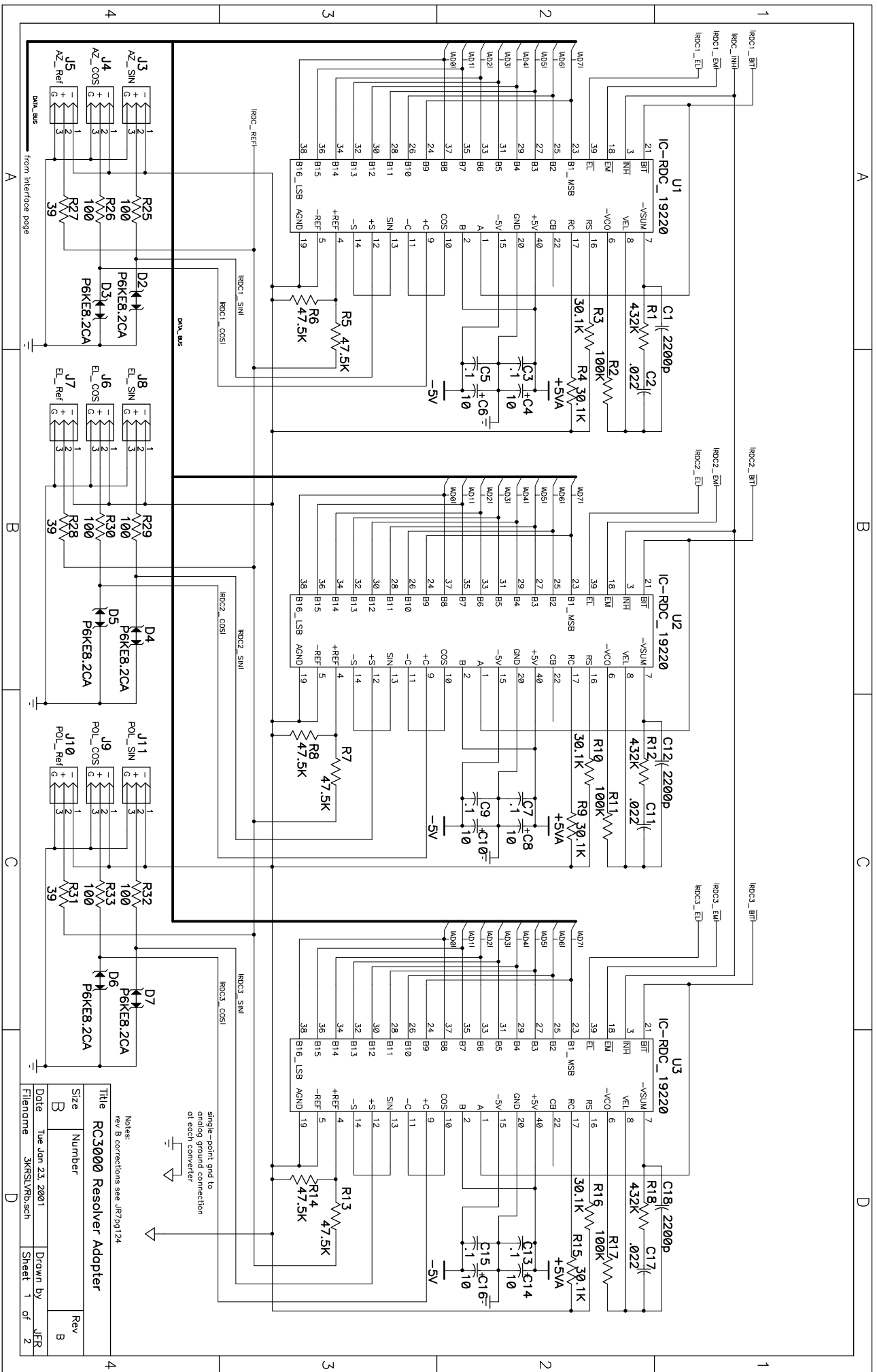

single-point gnd to
avoid ground connection
at each converter

Notes:
rev. B corrections see JFRPg124

Title
RC3000 Resolver Adapter

Size
Number

Date
Tue Jan 23, 2001

Filename
3KRS1VRS.sch

Drawn by
JFR

Sheet 1 of 2

Rev B

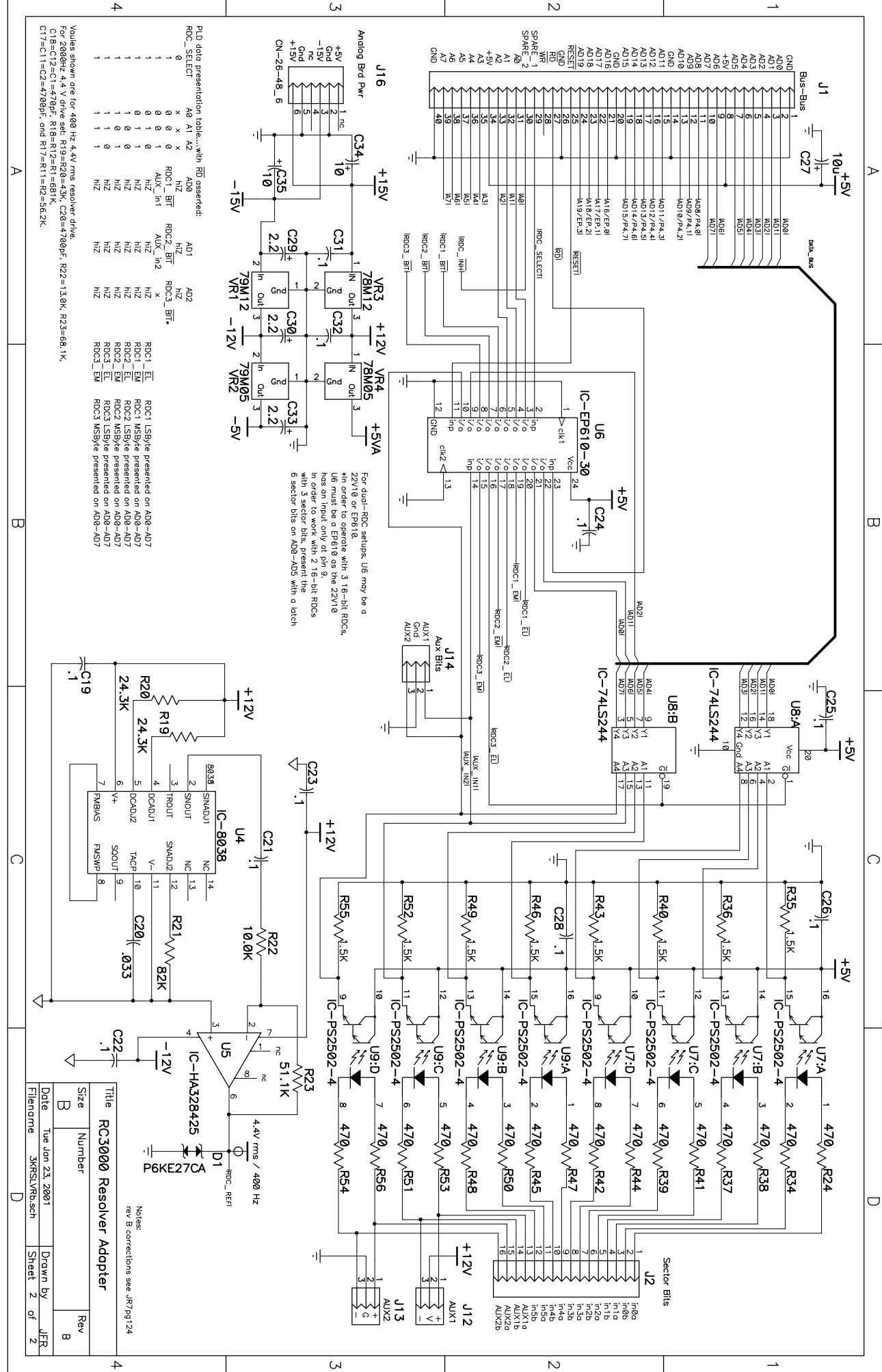

P.I.D. data presentation table...with RD asserted:

RD0	RD1	RD2	RD3	RD4	RD5	RD6	RD7
0	x	x	x	x	x	x	x
1	0	0	0	AD0	AD1	AD2	AD3
1	0	0	0	AD4	AD5	AD6	AD7
1	0	1	1	AD8	AD9	AD10	AD11
1	1	0	0	AD12	AD13	AD14	AD15
1	1	0	1	AD16	AD17	AD18	AD19
1	1	1	0	AD20	AD21	AD22	AD23
1	1	1	1	AD24	AD25	AD26	AD27

RD0	RD1	RD2	RD3	RD4	RD5	RD6	RD7
x	x	x	x	RD0	RD1	RD2	RD3
x	x	x	x	RD4	RD5	RD6	RD7
x	x	x	x	RD8	RD9	RD10	RD11
x	x	x	x	RD12	RD13	RD14	RD15
x	x	x	x	RD16	RD17	RD18	RD19
x	x	x	x	RD20	RD21	RD22	RD23
x	x	x	x	RD24	RD25	RD26	RD27

RD0	RD1	RD2	RD3	RD4	RD5	RD6	RD7
x	x	x	x	RD0	RD1	RD2	RD3
x	x	x	x	RD4	RD5	RD6	RD7
x	x	x	x	RD8	RD9	RD10	RD11
x	x	x	x	RD12	RD13	RD14	RD15
x	x	x	x	RD16	RD17	RD18	RD19
x	x	x	x	RD20	RD21	RD22	RD23
x	x	x	x	RD24	RD25	RD26	RD27

RD0	RD1	RD2	RD3	RD4	RD5	RD6	RD7
x	x	x	x	RD0	RD1	RD2	RD3
x	x	x	x	RD4	RD5	RD6	RD7
x	x	x	x	RD8	RD9	RD10	RD11
x	x	x	x	RD12	RD13	RD14	RD15
x	x	x	x	RD16	RD17	RD18	RD19
x	x	x	x	RD20	RD21	RD22	RD23
x	x	x	x	RD24	RD25	RD26	RD27

Notes:
rev B corrections see JFR79124

Title: RC3000 Resolver Adapter

Size: B
Number: B

Date: Tue Jan 23, 2001
Filename: 3KRS1VBR.sch
Drawn by: JFR
Sheet 2 of 2